

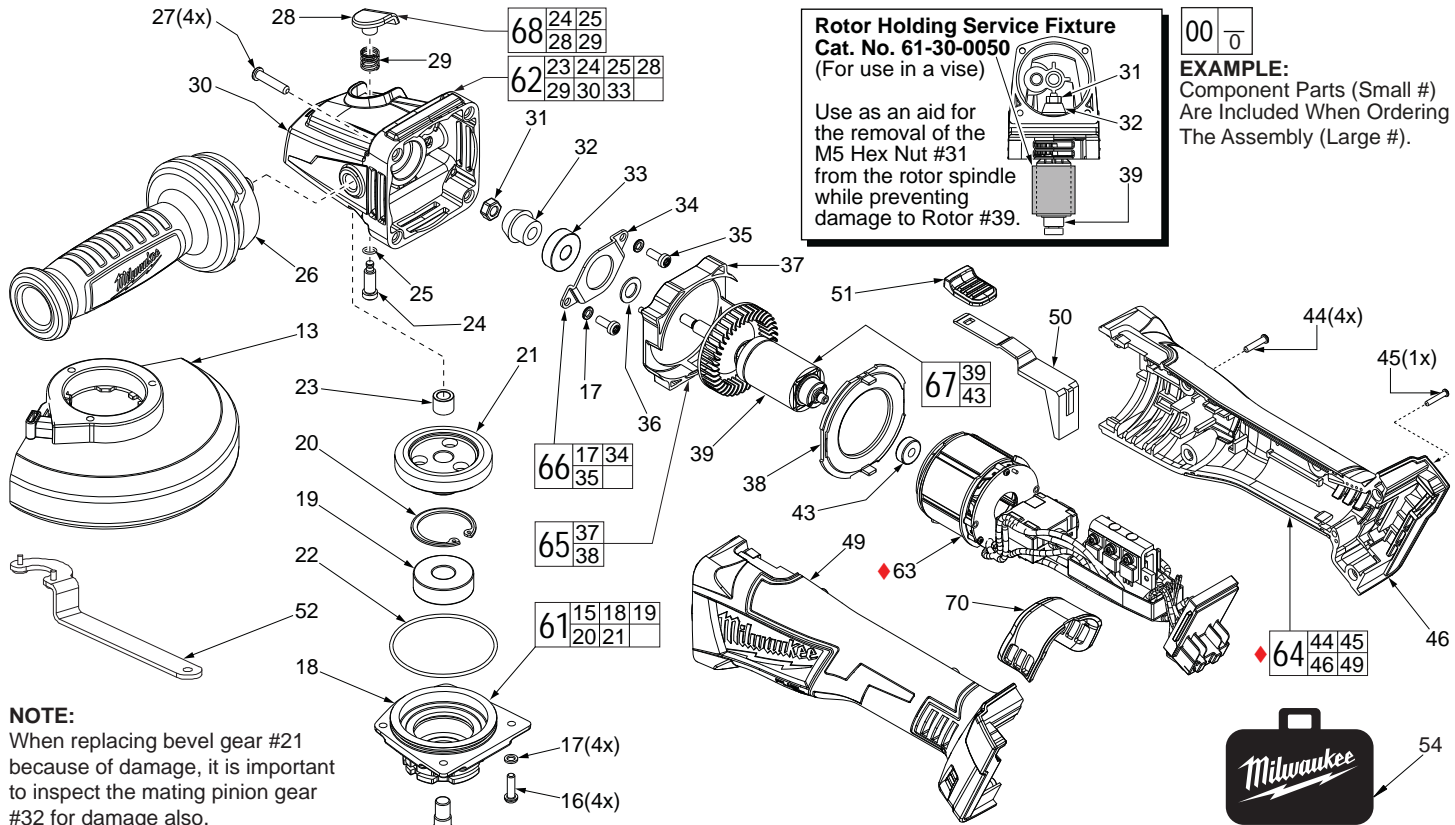

# SERVICE PARTS LIST

**BULLETIN NO.**  
**54-38-7000**

SPECIFY CATALOG NO. AND SERIAL NO. WHEN ORDERING PARTS		REVISED BULLETIN	DATE
<b>M18 FUEL™ Angle Grinder with Slide Switch &amp; Lock-On</b>			Apr. 2016
CATALOG NO. <b>2781-20</b>	STARTING SERIAL NO. <b>F32A</b>	WIRING INSTRUCTION <b>SEE PAGE 2</b>	



**NOTE:**  
When replacing bevel gear #21 because of damage, it is important to inspect the mating pinion gear #32 for damage also. It is recommended that gears be replaced in sets.

**\*LUBRICATION NOTE:**  
When servicing the Gears (21 & 32) or the Gearcase (30), 90-95% of the old grease must be removed prior to new grease being added.

**FIG. LUBRICATION\***  
21,32 Type "Y" Grease, No. 49-08-5270, Must Be Applied To All Gear Teeth.

**NOTE:**  
Early production of this model had an Electronics Assembly (63) that did not have a high voltage protection ground wire. The service replacement for the Electronics Assembly will have that wire. **If the tool being serviced needs a new Electronics package, Order Housing Kit 31-44-0895 also. Follow the wiring instructions on page two.**

FIG.	PART NO.	DESCRIPTION OF PART	NO. REQ.
1	44-40-0035	Flange Nut	1
3	43-34-0935	Flange Disc	1
4	-----	Flange with Ramps	1
5	-----	Retaining Ring	1
6	-----	Wave Spring	1
7	-----	O-Ring	1
13	14-32-0215	5" Type 27 Guard Assy. (Shown) (Standard)	1
13	43-54-0925	5" Type 1 Guard Assy. (Not Shown) (Standard)	1
13	14-32-0210	4.5" Type 27 Guard Assy. (Optional)	1
13	43-54-0920	4.5" Type 1 Guard Assy. (Optional)	1
15	-----	Output Shaft	1
16	05-88-1210	M4 x 14mm Pan Hd. T-20 Screw	4
17	05-90-0225	Spring Washer	6
18	-----	Spindle Hub	1
19	-----	Ball Bearing	1
20	-----	Retaining Ring	1
21	-----	Bevel Gear	1
22	34-40-0180	O-Ring	1
23	-----	Needle Bearing	1
24	-----	Spindle Lock Pin	1
25	-----	O-Ring	1
26	42-62-0125	Side Handle	1
27	05-88-1300	M4 x 28mm Pan Hd. ST T-20 Screw	4
28	-----	Spindle Lock Button	1

FIG.	PART NO.	DESCRIPTION OF PART	NO. REQ.
29	-----	Spindle Lock Spring	1
30	-----	Gearcase	1
31	05-55-0620	M5 Hex Nut	1
32	32-60-0165	Pinion	1
33	02-04-0620	Ball Bearing	1
34	44-66-0450	Bearing Retainer	1
35	05-88-1280	M4 x 10mm Pan Hd. T-20 Screw	2
36	45-88-0406	Washer	1
37	-----	Fan Baffle	1
38	-----	Fan Baffle Foot	1
39	-----	Rotor	1
43	02-04-0033	Ball Bearing	1
44	05-88-1200	M4 x 16mm Pan Hd. Plastite T-20 Screw	4
45	06-82-7236	4-20 x 5/8" Pan Hd. Plastite T-10 Screw	1
46	-----	Handle Cover - Right Side	1
49	-----	Handle Support - Left Side	1
50	31-84-0100	Slide Pole	1
51	31-92-0055	Slide Button	1
52	49-96-7205	Spanner Wrench	1
53	12-20-2685	Service Nameplate (Not Shown)	1
54	42-55-2694	Carrying Case	1
60	14-46-6105	Flange with Ramps Assembly	1
61	14-73-0428	Spindle Hub Assembly	1
62	14-30-1166	Gearcase Assembly	1
63	14-20-2685	Electronics Kit	1
64	31-44-0886	Housing Kit	1
65	42-14-0040	Baffle Assembly	1
66	44-86-0195	Bearing Retaining Plate Assembly	1
67	16-07-2690	Rotor Assembly	1
68	14-46-0630	Spindle Lock Kit	1
70	31-15-0275	Dust Cover	1

**MILWAUKEE ELECTRIC TOOL CORPORATION**  
13135 W. LISBON RD., BROOKFIELD, WI 53005  
Drwg. 6

# WIRE ROUTING AND TRAPPING for the ELECTRONICS KIT in the HANDLE SUPPORT (Left Handle Halve)

Route the voltage protection ground wire from the PCBA, through the traps in the left housing halve and place the wavy ring terminal over the screw boss as shown. Be sure to push wire firmly down into traps.

