



SERVICE PARTS LIST

BULLETIN NO.
54-38-2182

SPECIFY CATALOG NO. AND SERIAL NO. WHEN ORDERING PARTS		REVISED BULLETIN 54-38-2181	DATE Sept. 2017
5" HP RAT-TAIL ANGLE GRINDER with lock-on		WIRING INSTRUCTION See Reverse Side	
CAT. NO.	6124-30	STARTING SERIAL NUMBER	C99C

FIG.	PART NO.	DESCRIPTION OF PART	NO. REQ.
★ 1	05-88-1650	M4 x 25mm Pan Hd. ST Screw T-20	(7)
2	42-62-0125	Side Handle Assembly	(1)
★ 3	14-30-1156	Gearcase Assembly	(1)
3g	02-04-0620	Ball Bearing	(1)
4	34-40-0560	O-Ring	(1)
★ 5	14-73-0470	Spindle Hub Assembly	(1)
★ 5b	-----	Steel Pin	(1)
★ 5c	-----	Spring	(1)
★ 5d	44-20-0155	Guard Locking Tang	(1)
★ 5e	05-81-0020	M3 x 5mm Pan Hd. ST T-8 Screw	(1)

★ = Part number change from previous service parts list.

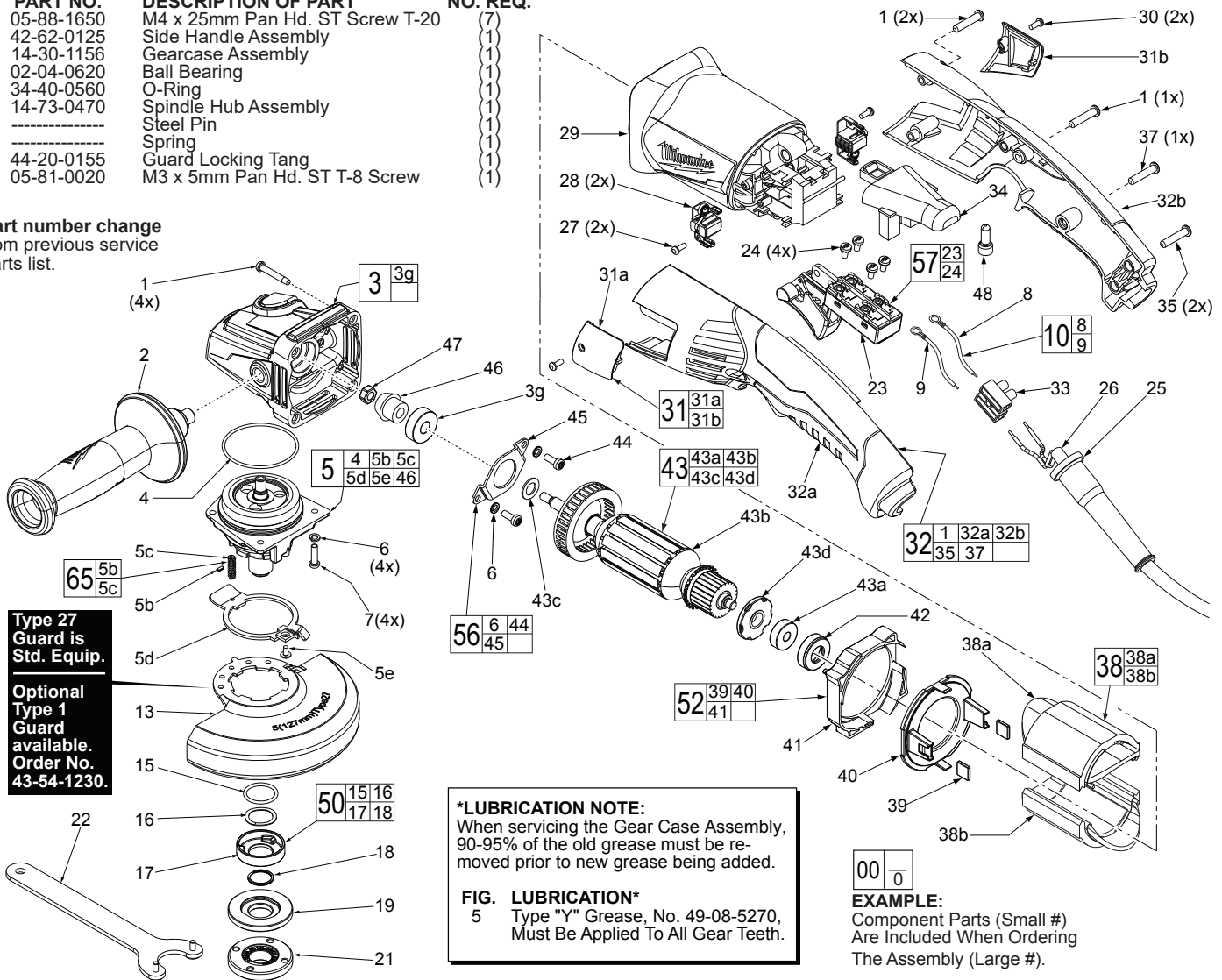

FIG.	PART NO.	DESCRIPTION OF PART	NO. REQ.
6	05-90-0225	Spring Washer	(6)
7	05-78-5316	M4 x 14mm Pan Hd. Tapt. Screw T-20	(4)
8	-----	Leadwire - Black	(1)
9	-----	Leadwire - White	(1)
10	23-94-0345	Leadwire Assy. Kit	(1)
★ 13	43-54-1220	5" Type 27 Guard (Standard Equip.)	(1)
★ 13	43-54-1230	5" Type 1 Guard (Optional, Not Shown)	(1)
15	-----	O-Ring	(1)
16	-----	Wavy Spring	(1)
17	-----	Flange with Ramps	(1)
18	-----	Retaining Ring	(1)
19	43-34-0935	Inner Disc Flange	(1)
21	44-40-0035	Outer Flange Nut	(1)
★ 22	49-96-7215	Spanner Wrench	(1)
23	-----	Trigger Switch	(1)
24	05-78-0305	M3.5 x 7mm Pan Hd. Phil. Switch Scr.	(4)
25	44-76-0095	Cord Protector	(1)
26	22-64-3425	Power Cord	(1)
27	05-88-0030	M3 x 8.5mm Pan Hd. ST Screw T-10	(2)
28	22-18-2250	Carbon Brush Assembly (Set of 2)	(1)
29	31-50-2140	Motor Housing	(1)
30	06-82-2395	M2.6 x 10mm Pan Hd. ST Screw T-9	(2)
31	31-15-1010	Brush Cover Assembly (Set of 2)	(1)
31a	-----	Brush Cover - Left	(1)
31b	-----	Brush Cover - Right	(1)
32	31-44-0705	Rear Handle Set (For lock-on switch)	(1)
32a	-----	Handle Halve - Left	(1)
32b	-----	Handle Halve - Right	(1)
33	22-56-0475	Terminal Connector Block	(1)
34	22-09-1850	PCB Assembly	(1)

FIG.	PART NO.	DESCRIPTION OF PART	NO. REQ.
35	05-88-1255	M4 x 22mm Pan Hd. ST T-20	(2)
37	06-82-1020	M4 x 14mm Pan Hd. ST T-20	(1)
38	18-07-0310	Field Assembly	(1)
38a	-----	Field Halve	(1)
38b	-----	Field Halve	(1)
39	42-28-0085	Rubber Block	(2)
40	-----	Baffle Foot	(1)
41	-----	Baffle	(1)
42	42-96-0016	Rubber Bearing Cap	(1)
43	16-10-0845	Armature Assembly	(1)
43a	02-04-2110	Ball Bearing	(1)
43b	-----	Armature	(1)
43c	45-88-0406	Washer	(1)
43d	-----	Magnetic Disc	(1)
44	05-78-0105	M4 x 10mm Pan Hd. Tapt. Screw T-20	(2)
45	44-86-0155	Bearing Retainer	(1)
★ 46	-----	Pinion	(1)
47	05-55-0620	M5 Hex Nut	(1)
48	22-56-0150	Close End Connector	(1)
50	14-46-6105	Flange with Ramps Assembly	(1)
52	42-14-0515	Baffle Assembly	(1)
56	44-86-0145	Bearing Retaining Plate Assembly	(1)
57	14-78-0550	Trigger Switch Assembly	(1)
★ 65	14-46-0241	Spring/Pin Kit	(1)
-----	12-20-1560	Service Nameplate (Not Shown)	(1)
-----	10-20-2225	Bi-Lingual Warning Label (Not Shown)	(1)

AS AN AID TO REASSEMBLY, TAKE NOTICE OF WIRE ROUTING AND POSITION IN WIRE GUIDES AND TRAPS WHILE DISMANTLING TOOL.

BE CAREFUL AND AVOID PINCHING WIRES BETWEEN HANDLE HALVES WHEN ASSEMBLING.

Be sure to fully seat 'T1' onto the post in the left handle half.

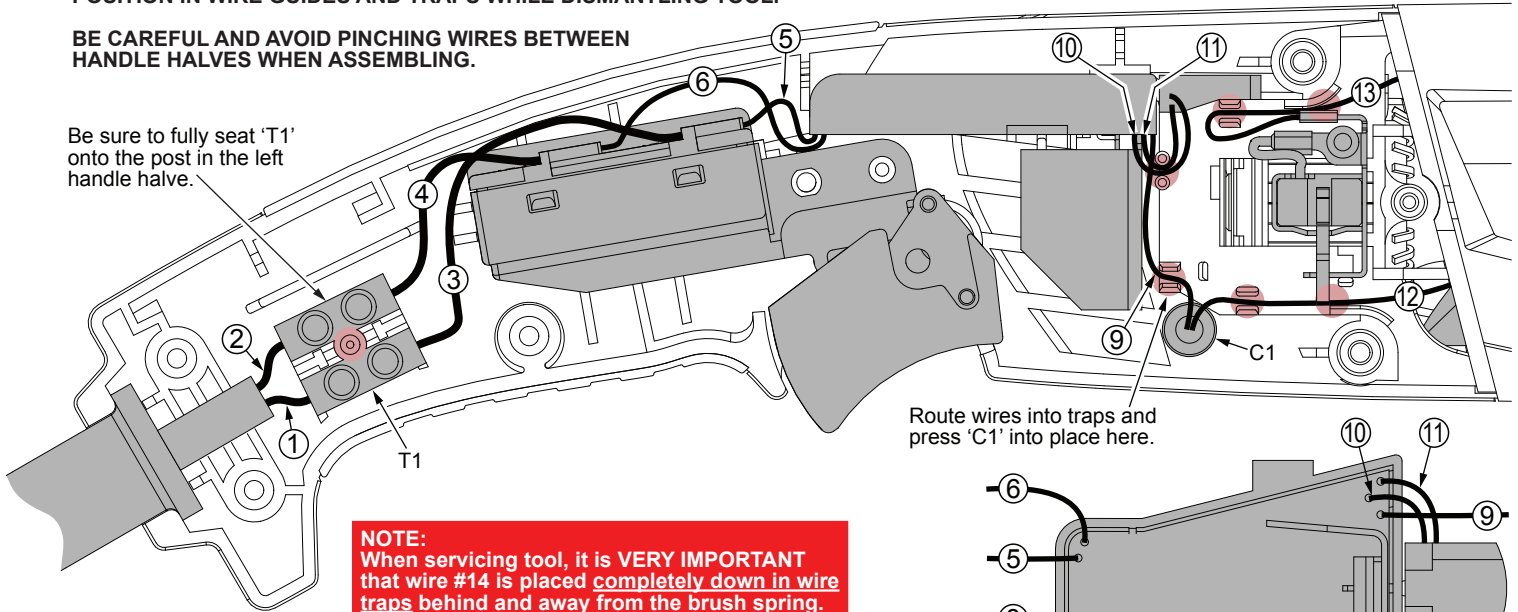

Route wires into traps and press 'C1' into place here.

NOTE: When servicing tool, it is VERY IMPORTANT that wire #14 is placed completely down in wire traps behind and away from the brush spring.

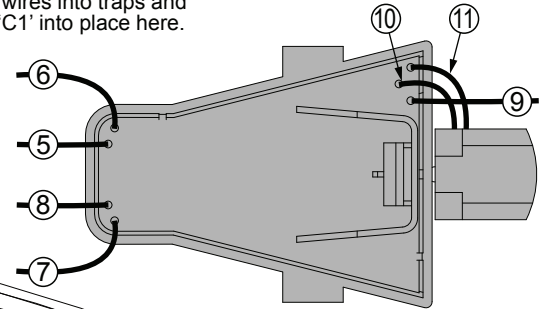

Bottom View of the PCB Assembly

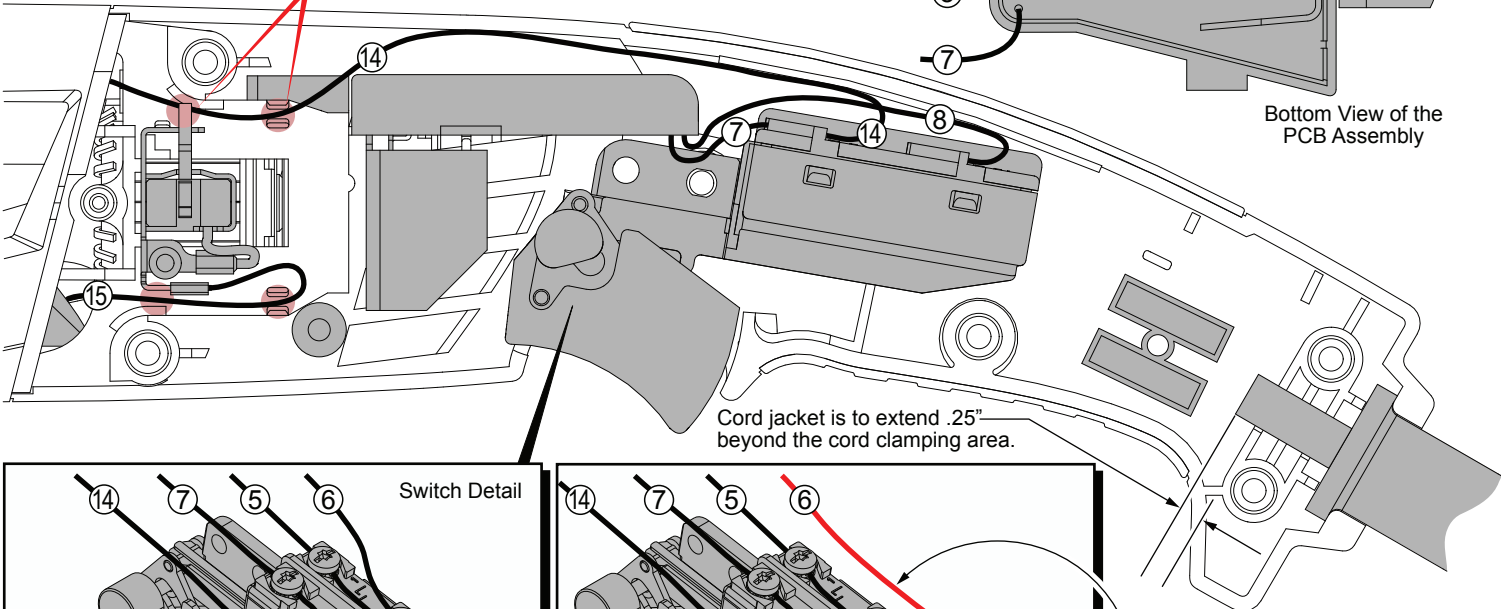

Cord jacket is to extend .25" beyond the cord clamping area.

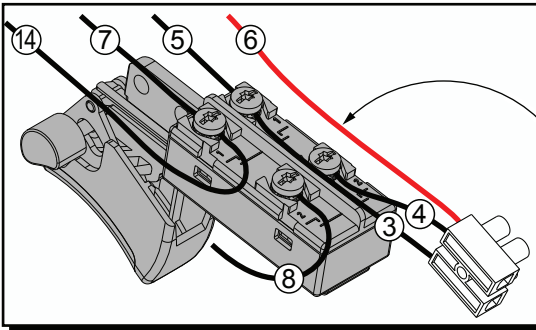
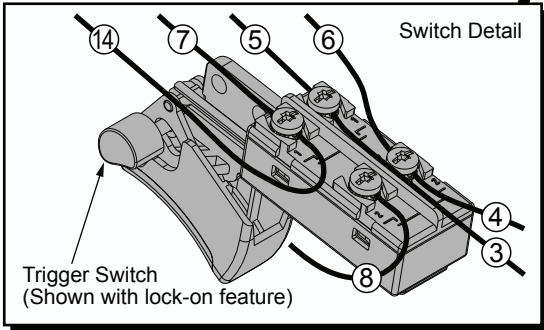

● = WIRE TRAPS or GUIDES

NOTE: PCBA wire #6 can be routed to the lower right switch position or connect with white wire #4 in terminal block T1 as shown .

WIRING SPECIFICATIONS

Wire No.	Wire Color	Origin or Part No.	Gauge	Length	Terminals, Connectors and End Wire Preparation
1	Black	22-64-3425	--	--	Component of Cord Set. Connect to T1 as shown.
2	White	22-64-3425	--	--	Component of Cord Set. Connect to T1 as shown.
3	Black	23-94-0345	--	--	Comp. of Leadwire Assembly Kit. Connect to Switch and T1 as shown.
4	White	23-94-0345	--	--	Comp. of Leadwire Assembly Kit. Connect to Switch and T1 as shown.
5	Black	22-09-1850	--	--	Comp. of PCB Assembly. Connect to Switch as shown.
6	White	22-09-1850	--	--	Comp. of PCB Assy. Connect to Switch or T1 as shown.
7	Black	22-09-1850	--	--	Comp. of PCB Assembly. Connect to Switch as shown.
8	White	22-09-1850	--	--	Comp. of PCB Assembly. Connect to Switch as shown.
9	Red	22-09-1850	--	--	Comp. of PCB Assembly. Connect to Wire #12 with C1.
10	Black	22-09-1850	--	--	Component of PCB Assembly.
11	White	22-09-1850	--	--	Component of PCB Assembly.
12	Black	18-07-0310	--	--	Comp. of Field. Connect to Wire #9 with C1 as shown.
13	Black	18-07-0310	--	--	Comp. of Field. Connect to Right Brush Assy. as shown.
14	Black	18-07-0310	--	--	Component of Field. Connect to Switch as shown.
15	Black	18-07-0310	--	--	Comp. of Field. Connect to Left Brush Assy. as shown.

BULK LEAD WIRE - BULLETIN 58-01-0003

NOTE: All leads must be held to ± 1/16". All lead lengths are before stripping.

TERMINAL DESCRIPTION		
Code	Part No.	Qty.
T1	22-56-0475	1
CONNECTOR DESCRIPTION		
C1	22-56-0150	1