

Top-Lok

PARTING & GROOVING

For more ordering information, check out our new Turning tools catalog.



Allow us to introduce our new catalogs

In your hands, you have one of our latest brochures or catalogs. It includes several new features. Find out more about what's new below.



- Includes CoroPak 11.1
- Two parts, more user-friendly
- Metric and inch assortment

What's new?

There are two parts; rotating and turning tools and all the news from CoroPak 11.1 is included.

Rotating tools – milling, drilling, boring and related tooling systems

Turning tools – general turning, parting & grooving, threading and related tooling systems

More information about the new tools and machining solutions is presented in a new brochure, New cutting tools and solutions.

Where to find ...

... ordering information, dimensions, cutting data:

in catalog Rotating tools or Turning tools
or, for new tools from 11.2, in a CoroPak Supplement

... more information about new cutting tools and machining solutions:

in New cutting tools and solutions.

To quickly get you started

The CoroKey guide provides a first-choice selection of tools, inserts and cutting data.

It's all online

You can download all catalogs, brochures and technical guides from our website, www.sandvik.coromant.com. You can also get a DVD version that includes all latest catalogs, New cutting tools and solutions and the Technical Guide. The DVD contains active links, illustrative animations and many film sequences. To order your copy of the DVD or any other printed media, contact your nearest sales representative or order it at www.sandvik.coromant.com.

our website is always updated with the latest information.





Appears from 11.2



- Easier to find information
- Includes the latest machining solutions

Insert overview

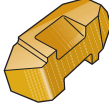
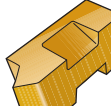
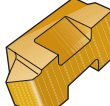
Parting and grooving inserts

	Grooving Top-Lok®			Threading Top-Lok®			Bear Paw
							
	TLG	TLGP	TLR	TLTP	TLTF	TLTK	BP
Insert width, inch	.031-.250	.031-.250	.062-.250	-	-	-	.500-.750
Page							

Toolholder overview

Coromant Capto® cutting units for parting and grooving

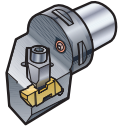
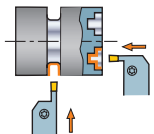
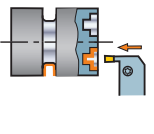
Top-Lok®	Grooving	Face grooving
		
	Cx-TLSR/L	Cx-TLER/L
Insert width, inch	.031-.250	.031-.250
Coromant Capto® size	C3-C6	C4-C6
Page		

Shank tools for parting and grooving

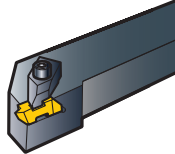
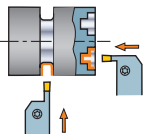
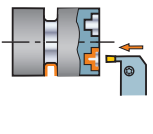
Top-Lok®	Grooving	Face grooving 0°
		
	TLSR/L	TLER/L
Insert width, inch	.031-.250	.031-.250
Shank size, inch	.500-1.250	.500-1.250
Shank dim., mm	-	-
Page		

Boring bars for parting and grooving

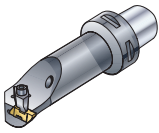
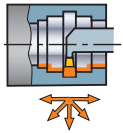
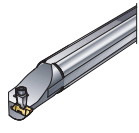
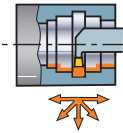
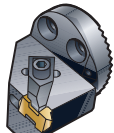
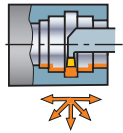
Top-Lok® Coromant Capto®	Grooving	Top-Lok®	Grooving	Top-Lok® grooving head	Grooving
					
	Cx-CTLHOR/L		SI-CTLHOR/L		570C-TLER/L
Insert width, inch	.031-.250	Insert width, inch	.031-.250	Insert width, inch	.031-.250
Coromant Capto® size	C4-C6	Min. bore, inch	1.000-2.750	Coupling size, mm	20-40
Page		Bar diameter, inch	.625-2.000	Page	

Shank tools for parting and grooving

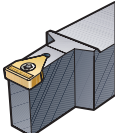
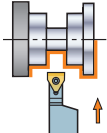
Bear Paw	Grooving
	
	BPGN BPGR/L
Insert width, inch	.500-.750 .500-.750
Shank size, inch	1.250-1.500 1.500
Page	

Parting blades

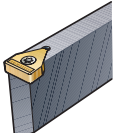
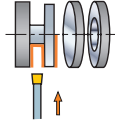
Bear Paw double ended grooving blade	Parting off
	
	BPR/L
Insert width, inch	.500-.750
Max a, inch	3.93
Page	

Complementary systems with grooving and profiling geometries















Top-Lok®

The Top-Lok clamping system locks the insert against both the back and side of the pocket, providing clamping integrity axially and radially.

- Precision ground inserts.
- Interchangeable with similar clamping systems.
- Double-ended inserts provide maximum edge security.

Bear Paw

Bear paw for heavy duty external grooving applications with insert widths of .500, .625 and .750 inch. Special widths and corner radii available upon request.

Application	Low feed		Medium feed		High feed		
	 Top-Lok		 Top-Lok		 Bear Paw	 Heavy Duty	 T-Max U-Lock
External grooving	 TLGP		 TLG		 BP	 HDG	
Internal grooving	 TLGP		 TLG			 154.0	
Profiling		 TLRP		 TLR			

Grades

Above systems available in different carbide grades to cover most types of workpiece materials.

ISO P = Steel

ISO M = Stainless steel

ISO K = Cast iron

ISO N = Aluminum and non-ferrous materials

ISO S = Heat resistant super alloys

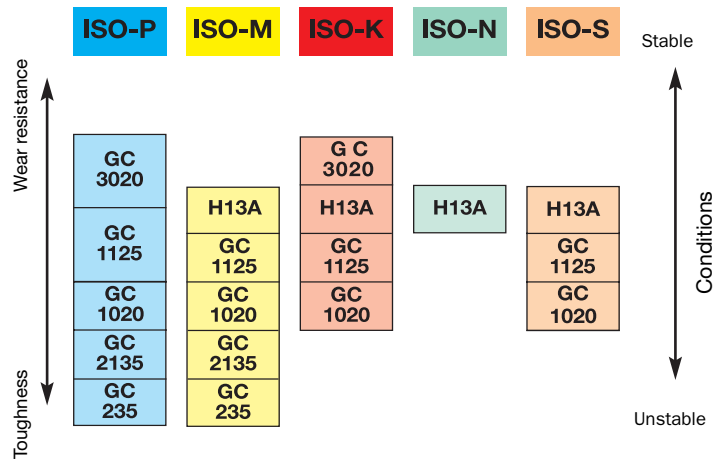

Top-Lok®

Grooving inserts

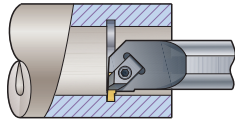
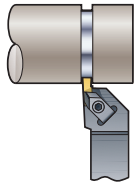

Neutral precision
TLG

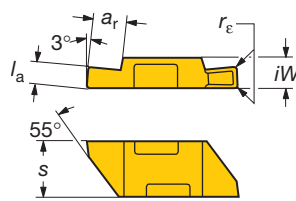

Tolerances:

$l_a = \pm .001$ inch

For ISO application areas, see bottom of the table.

Right hand style shown

Insert size	Ordering code	Dimensions										P		M		K		N		S		
		l_a	l_a	s	a_r	r_e	r_e	r_e	r_e	iW	GC	GC	GC	GC	GC	GC	GC	GC	GC	GC	GC	
		mm	inch			min	min	max	max		1125	2135	3020	1125	2135	3020	1125	2135	3020	1125	2135	
TLG	TLG-2031R/L	0.79	.031	.219	.050	0.05	.002	0.13	.005	.150	★	★		★	★		★	★		★	★	
	TLG-2041L	1.04	.041	.219	.050	0.05	.002	0.13	.005	.150	★	★		★	★		★	★		★	★	
	TLG-2041R	1.04	.041	.219	.050	0.05	.002	0.13	.005	.150	★	★		★	★		★	★		★	★	
	TLG-2047L	1.19	.047	.219	.050	0.05	.002	0.13	.005	.150	★	★		★	★		★	★		★	★	
	TLG-2047R	1.19	.047	.219	.050	0.05	.002	0.13	.005	.150	★	★		★	★		★	★		★	★	
	TLG-2058L	1.47	.058	.219	.050	0.13	.005	0.25	.010	.150	★	★		★	★		★	★		★	★	
	TLG-2058R	1.47	.058	.219	.050	0.13	.005	0.25	.010	.150	★	★		★	★		★	★		★	★	
	TLG-2062L	1.57	.062	.219	.110	0.13	.005	0.25	.010	.150	★	★	★	★	★		★	★		★	★	
	TLG-2062R	1.57	.062	.219	.110	0.13	.005	0.25	.010	.150	★	★		★	★		★	★		★	★	
	TLG-2094L	2.39	.094	.219	.110	0.13	.005	0.25	.010	.150	★	★	★	★	★		★	★		★	★	
	TLG-2094R	2.39	.094	.219	.110	0.13	.005	0.25	.010	.150	★	★		★	★		★	★		★	★	
	TLG-2125L	3.17	.125	.219	.110	0.13	.005	0.25	.010	.150	★	★		★	★		★	★		★	★	
	TLG-2125R	3.17	.125	.219	.110	0.13	.005	0.25	.010	.150	★	★		★	★		★	★		★	★	
		TLG-3047L	1.19	.047	.344	.075	0.13	.005	0.25	.010	.195	★	★		★	★		★	★		★	★
TLG-3047R		1.19	.047	.344	.075	0.13	.005	0.25	.010	.195	★	★		★	★		★	★		★	★	
TLG-3062L		1.57	.062	.344	.094	0.13	.005	0.25	.010	.195	★	★		★	★		★	★		★	★	
TLG-3062R		1.57	.062	.344	.094	0.13	.005	0.25	.010	.195	★	★		★	★		★	★		★	★	
TLG-3072L		1.83	.072	.344	.094	0.13	.005	0.25	.010	.195	★	★		★	★		★	★		★	★	
TLG-3072R		1.83	.072	.344	.094	0.13	.005	0.25	.010	.195	★	★		★	★		★	★		★	★	
TLG-3078L		1.98	.078	.344	.094	0.13	.005	0.25	.010	.195	★	★		★	★		★	★		★	★	
TLG-3078R		1.98	.078	.344	.094	0.13	.005	0.25	.010	.195	★	★		★	★		★	★		★	★	
TLG-3088L		2.24	.088	.344	.094	0.13	.005	0.25	.010	.195	★	★		★	★		★	★		★	★	
TLG-3088R		2.24	.088	.344	.094	0.13	.005	0.25	.010	.195	★	★		★	★		★	★		★	★	
TLG-3094L		2.39	.094	.344	.150	0.13	.005	0.25	.010	.195	★	★		★	★		★	★		★	★	
TLG-3094R		2.39	.094	.344	.150	0.13	.005	0.25	.010	.195	★	★		★	★		★	★		★	★	
TLG-3097L		2.46	.097	.344	.150	0.25	.010	0.38	.015	.195	★	★		★	★		★	★		★	★	
TLG-3097R		2.46	.097	.344	.150	0.25	.010	0.38	.015	.195	★	★		★	★		★	★		★	★	
TLG-3105L		2.67	.105	.344	.150	0.13	.005	0.25	.010	.195	★	★		★	★		★	★		★	★	
TLG-3105R		2.67	.105	.344	.150	0.13	.005	0.25	.010	.195	★	★		★	★		★	★		★	★	
TLG-3110R/L		2.79	.110	.344	.150	0.25	.010	0.38	.015	.195	★	★		★	★		★	★		★	★	
TLG-3122R/L		3.10	.122	.344	.150	0.13	.005	0.25	.010	.195	★	★		★	★		★	★		★	★	
TLG-3125R/L		3.17	.125	.344	.150	0.13	.005	0.25	.010	.195	★	★		★	★		★	★		★	★	
TLG-3142R/L		3.61	.142	.344	.150	0.25	.010	0.38	.015	.195	★	★		★	★		★	★		★	★	
TLG-3156L	3.96	.156	.344	.150	0.13	.005	0.25	.010	.195	★	★		★	★		★	★		★	★		
TLG-3156R	3.96	.156	.344	.150	0.13	.005	0.25	.010	.195	★	★		★	★		★	★		★	★		
TLG-3178L	4.52	.178	.344	.150	0.13	.005	0.25	.010	.195	★	★		★	★		★	★		★	★		
TLG-3185R/L	4.70	.185	.344	.150	0.51	.020	0.63	.025	.195	★	★		★	★		★	★		★	★		
TLG-3189R/L	4.80	.189	.344	.150	0.51	.020	0.63	.025	.195	★	★		★	★		★	★		★	★		
	TLG-4125R/L	3.17	.125	.453	.150	0.13	.005	0.25	.010	.255	★	★		★	★		★	★		★	★	
	TLG-4189L	4.80	.189	.453	.250	0.51	.020	0.63	.025	.255	★	★		★	★		★	★		★	★	
	TLG-4189R	4.80	.189	.453	.250	0.51	.020	0.63	.025	.255	★	★		★	★		★	★		★	★	
	TLG-4213R/L	5.41	.213	.453	.250	0.13	.005	0.25	.010	.255	★	★		★	★		★	★		★	★	
	TLG-4250L	6.35	.250	.453	.250	0.51	.020	0.63	.025	.255	★	★		★	★		★	★		★	★	
	TLG-4250R	6.35	.250	.453	.250	0.51	.020	0.63	.025	.255	★	★		★	★		★	★		★	★	
											P30	P35	P15	M25	M30	M15	K30	K15	K20	N20	S25	S15

R = Right hand, L = Left hand
★ = First choice

Top-Lok®

Grooving inserts

Positive precision TLGP

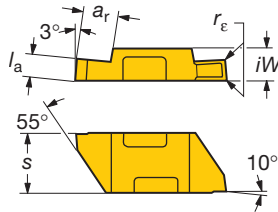
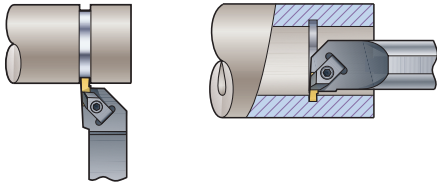

Tolerances:

$l_a = \pm .001$ inch

For ISO application areas, see bottom of the table.

Right hand style shown

Insert size	Ordering code	Dimensions										P		M		K		N		S			
		l_a	l_a	s	a_r	r_ϵ	r_ϵ	r_ϵ	r_ϵ	iW	GC	GC	GC	GC	GC	GC	GC	GC	GC	GC	GC		
		mm	inch			min	min	max	max		1125	2135	1125	2135	1125	3020	1125	3020	1125	3020			
TLGP	2	TLGP-2031R/L	0.79	.031	.219	.050	0.05	.002	0.13	.005	.150	★	☆	★	☆	★	☆	★	☆	★	☆		
		TLGP-2041L	1.04	.041	.219	.050	0.05	.002	0.13	.005	.150	★		★		★		★		★			
		TLGP-2041R	1.04	.041	.219	.050	0.05	.002	0.13	.005	.150	★	☆	★	☆	★		★		★			
		TLGP-2047L	1.19	.047	.219	.050	0.05	.002	0.13	.005	.150	★		★		★		★		★			
		TLGP-2047R	1.19	.047	.219	.050	0.05	.002	0.13	.005	.150	★	☆	★	☆	★		★		★			
		TLGP-2058R/L	1.47	.058	.219	.050	0.13	.005	0.25	.010	.150	★		★		★		★		★			
		TLGP-2062R/L	1.57	.062	.219	.110	0.13	.005	0.25	.010	.150	★	☆	★	☆	★		★	☆	★	☆		
		TLGP-2094R/L	2.39	.094	.219	.110	0.13	.005	0.25	.010	.150	★		★		★		★		★			
		TLGP-2125R/L	3.17	.125	.219	.110	0.13	.005	0.25	.010	.150	★		★		★		★		★			
		3	TLGP-3047L	1.19	.047	.344	.075	0.13	.005	0.25	.010	.195	★		★		★		★		★		
			TLGP-3047R	1.19	.047	.344	.075	0.13	.005	0.25	.010	.195	★	☆	★	☆	★		★		★		
			TLGP-3062R/L	1.57	.062	.344	.094	0.13	.005	0.25	.010	.195	★	☆	★	☆	★		★		★		
		TLGP-3072L	1.83	.072	.344	.094	0.13	.005	0.25	.010	.195	★		★		★		★		★			
		TLGP-3072R	1.83	.072	.344	.094	0.13	.005	0.25	.010	.195	★	☆	★	☆	★		★		★			
		TLGP-3078R/L	1.98	.078	.344	.094	0.13	.005	0.25	.010	.195	★		★		★		★		★			
		TLGP-3088R/L	2.24	.088	.344	.094	0.13	.005	0.25	.010	.195	★		★		★		★		★	☆		
		TLGP-3094R/L	2.39	.094	.344	.150	0.13	.005	0.25	.010	.195	★	☆	★	☆	★		★		★			
		TLGP-3097R	2.46	.097	.344	.150	0.25	.010	0.38	.015	.195	★		★		★		★		★			
		TLGP-3105R/L	2.67	.105	.344	.150	0.13	.005	0.25	.010	.195	★		★		★		★		★			
		TLGP-3110R/L	2.79	.110	.344	.150	0.25	.010	0.38	.015	.195	★		★		★		★		★			
		TLGP-3122R	3.10	.122	.344	.150	0.13	.005	0.25	.010	.195	★		★		★		★		★			
		TLGP-3125R/L	3.17	.125	.344	.150	0.13	.005	0.25	.010	.195	★	☆	★	☆	★		★	☆	★	☆		
		TLGP-3142R/L	3.61	.142	.344	.150	0.25	.010	0.38	.015	.195	★	☆	★	☆	★		★		★			
		TLGP-3156L	3.96	.156	.344	.150	0.13	.005	0.25	.010	.195	★		★		★		★		★			
		TLGP-3156R	3.96	.156	.344	.150	0.13	.005	0.25	.010	.195	★	☆	★	☆	★		★		★			
		TLGP-3178R	4.52	.178	.344	.150	0.13	.005	0.25	.010	.195	★		★		★		★		★			
		TLGP-3185R	4.70	.185	.344	.150	0.51	.020	0.63	.025	.195	★		★		★		★		★			
		TLGP-3189L	4.80	.189	.344	.150	0.51	.020	0.63	.025	.195	★		★		★		★		★	☆		
		TLGP-3189R	4.80	.189	.344	.150	0.51	.020	0.63	.025	.195	★		★		★		★		★	☆		
	4	TLGP-4125R/L	3.17	.125	.453	.150	0.13	.005	0.25	.010	.255	★		★		★		★		★			
		TLGP-4189R/L	4.80	.189	.453	.250	0.51	.020	0.63	.025	.255	★		★		★		★		★	☆		
		TLGP-4250R/L	6.35	.250	.453	.250	0.51	.020	0.63	.025	.255	★		★		★		★		★			
												P30	P35	P15	M25	M30	M15	K30	K15	K20	N20	S25	S15

R = Right hand, L = Left hand
★ = First choice

Top-Lok®

Grooving inserts

Full radius

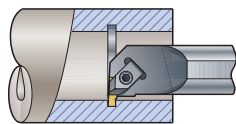
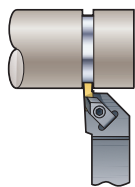

Neutral precision

TLR

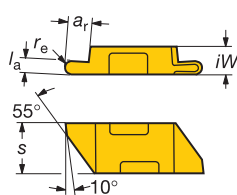

Tolerances:

$l_a = \pm .001$ inch

For ISO application areas, see bottom of the table.

Right hand style shown

	Insert size	Ordering code	Dimensions							Material														
			l_a inch	l_a mm	s	a_r	r_e inch	r_e mm	i/W	P			M			K			N			S		
										GC	GC	GC	GC	GC	GC	GC	GC	GC	GC	GC	GC	GC	GC	GC
TLR	3	TLR-3031R/L	.062	1.57	.344	.094	.031	0.79	.195	☆	☆	☆	☆	☆	☆	☆	☆	☆	☆	☆	☆	☆	☆	☆
		TLR-3047R/L	.094	2.39	.344	.150	.047	1.19	.195	☆	☆	☆	☆	☆	☆	☆	☆	☆	☆	☆	☆	☆	☆	☆
		TLR-3062R/L	.124	3.15	.344	.150	.062	1.57	.195	☆	☆	☆	☆	☆	☆	☆	☆	☆	☆	☆	☆	☆	☆	☆
		TLR-3078L	.156	3.96	.344	.150	.078	1.98	.195	☆	☆	☆	☆	☆	☆	☆	☆	☆	☆	☆	☆	☆	☆	☆
		TLR-3078R	.156	3.96	.344	.150	.078	1.98	.195	★	★	★	★	★	★	★	★	★	★	★	★	★	★	★
		TLR-3094L	.188	4.78	.344	.150	.094	2.39	.195	★	★	★	★	★	★	★	★	★	★	★	★	★	★	★
	TLR-3094R	.188	4.78	.344	.150	.094	2.39	.195	★	★	★	★	★	★	★	★	★	★	★	★	★	★	★	
	4	TLR-4062R/L	.124	3.15	.453	.150	.062	1.57	.255	★	★	★	★	★	★	★	★	★	★	★	★	★	★	★
		TLR-4094R/L	.188	4.78	.453	.250	.094	2.39	.255	★	★	★	★	★	★	★	★	★	★	★	★	★	★	★
		TLR-4125R/L	.250	6.35	.453	.250	.125	3.17	.255	☆	☆	☆	☆	☆	☆	☆	☆	☆	☆	☆	☆	☆	☆	☆
										P30	P35	P15	M25	M30	M15	K30	K15	K20	N20	S25	S15			

R = Right hand, L = Left hand

★ = First choice

Top-Lok®

60° V-profile

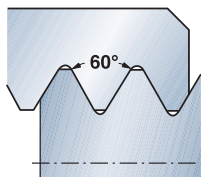

Non-topping
TLTP 5° positive

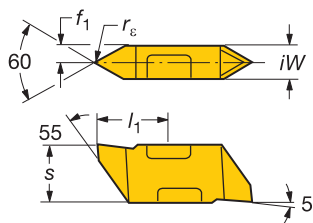

Non-topping, fine pitch, close to shoulder
TLTF Neutral

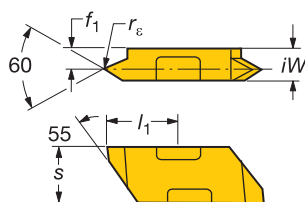

TLTK 5° positive

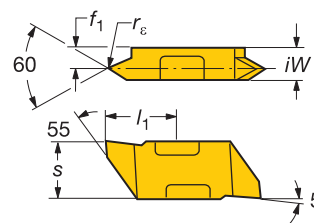

For ISO application areas, see bottom of the table.

Right hand style shown

	Insert size	Pitch range TPI ²⁾	Ordering code	Dimensions					ISO Application Areas								
				s	f ₁	l ₁ ¹⁾	r _e	iW	P	M	K	N	S				
									GC	GC	GC	GC	GC				
	2		TLTP-2R/L	.219	.075	.266	.003-.005	.150	☆	☆	☆	☆	☆	☆	☆		
	3		TLTP-3004R/L	.344	.098	.399	.003-.005	.195	☆	☆	☆	☆	☆	☆	☆		
			TLTP-3R/L	.344	.098	.399	.005-.008	.195	☆	☆	☆	☆	☆	☆	☆		
	4		TLTP-4R/L	.453	.128	.630	.005-.008	.255	☆	☆	☆	☆	☆	☆	☆		
	2		TLTF-2R/L	.219	.110	.266	.002-.004	.150	☆	☆	☆	☆	☆	☆	☆		
	3		TLTF-3R/L	.344	.141	.402	.002-.004	.195	☆	☆	☆	☆	☆	☆	☆		
	2		TLTK-2R/L	.219	.110	.266	.002-.004	.150	☆	☆	☆	☆	☆	☆	☆		
	3		TLTK-3R/L	.344	.141	.402	.002-.004	.195	☆	☆	☆	☆	☆	☆	☆		
									P20	M20	M25	K15	K20	N20	N25	S20	S25

1) Over theoretical sharp corner
2) For pitch recommendations see page .

R = Right hand, L = Left hand

Note: inserts in grade H13A have a sharp cutting edge without ER treatment.

TLTP 3 004 R
 | | |
 | | | Radius
 | | | Insert size
 P = Positive
 F = Fine pitch
 K = Fine pitch positive

60° V-profile application data

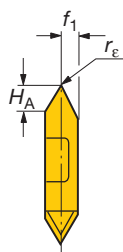

TLTP

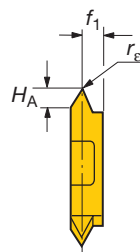
TLTF
TLTK

Feed direction



Feed direction

Insert	Dimensions			Recommended threads per inch TPI		Recommended thread pitch Metric	
	H_A	f_1	r_ϵ	External	Internal	External	Internal
TLTP 2R/L	.113	.075	.003-.005	36-8	20-7	0.70-3.00	1.25-3.50
TLTP 3R/L	.148	.098	.005-.008	20-5	12-5	1.25-4.00	2.00-5.00
TLTP 4R/L	.196	.128	.005-.008	20-4	12-4	1.25-6.25	2.00-6.25
TLTP 3004R/L	.148	.098	.003-.005	36-5	12-5	1.25-4.00	2.00-5.00
TLTF 2R/L	.062	.110	.002-.004	44-14	24-12	0.60-1.75	1.00-2.00
TLTF 3R/L	.083	.141	.002-.004	44-10	24-9	0.60-2.50	1.00-2.50
TLTK 2R/L	.062	.110	.002-.004	44-14	24-12	0.60-1.75	1.00-2.00
TLTK 3R/L	.083	.141	.002-.004	44-10	24-9	0.60-2.50	1.00-2.50

Coromant Capto® cutting units

Clamp design

Cx-TLSR/L

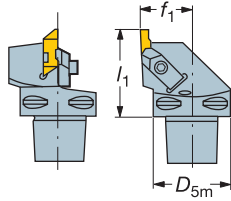

Note: Right hand tools use right hand inserts.

Left hand tools use left hand inserts.

Right hand style shown

Main application	Insert size	Ordering code	Dimensions			Gauge inserts
			D_{5m}	$f_1^{1)}$	l_1	
	2	C3-TLSR-22040-2	1.260	.866	1.575	TLG 2
		C4-TLSR/L-27050-2	1.575	1.063	1.969	TLG 2
	3	C3-TLSR-22045-3	1.260	.866	1.772	TLG 3
		C4-TLSR/L-27050-3	1.575	1.063	1.969	TLG 3
		C5-TLSR/L-35060-3	1.968	1.378	2.362	TLG 3
	4	C6-TLSR/L-45065-3	2.480	1.772	2.559	TLG 3
		C4-TLSR-27055-4	1.575	1.063	2.165	TLG 4
		C5-TLSR-35060-4	1.968	1.378	2.362	TLG 4
	C6-TLSR/L-45065-4	2.480	1.772	2.559	TLG 4	

1) f_1 dimension qualified over sharp point of insert.

R = Right hand, L = Left hand

Coromant Capto® cutting units

Clamp design

Cx-TLER/L

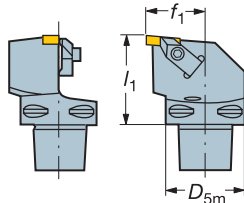

Right hand tools use left hand inserts.

Left hand tools use right hand inserts

Right hand style shown

Main application	Insert size	Ordering code	Dimensions			Gauge inserts
			D_{5m}	$f_1^{1)}$	l_1	
	3	C4-TLER/L-27050-3	1.575	1.063	1.969	TLG 3
		C5-TLER/L-35060-3	1.968	1.378	2.362	TLG 3
		C6-TLER/L-45065-3	2.480	1.772	2.559	TLG 3

1) f_1 dimension qualified over sharp point of insert.

R = Right hand, L = Left hand

Main spare parts

		Clamp			
Tool type	Insert size	Right hand	Left hand	Clamping screw (thread)	Key (inch)
TLSR/L	2	C2R	C2L	10440 (6-32)	3021 011-764 ($7/64$)
	3	C3R	C3L	10090 (10-32)	3021 010-040 ($5/32$)
	4	C4R	C4L	10090 (10-32)	3021 010-040 ($5/32$)
TLER/L	3	C3R	C3L	10090 (10-32)	3021 010-040 ($5/32$)

Shank tools

Clamp design

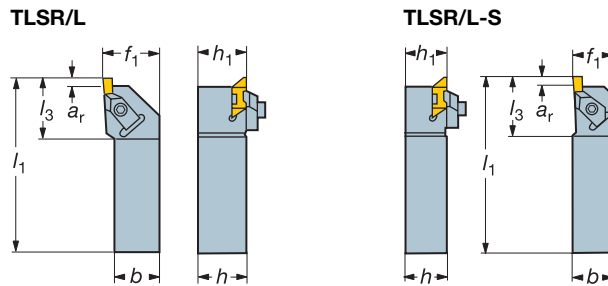

Note!

a_r of the insert gives the maximum depth of cut.

Note: Right hand tools use right hand inserts.

Left hand tools use left hand inserts.

Right hand style shown

Main application	Insert size	Ordering code	Dimensions							Gauge inserts	
			a_r	b	$f_1^{1)}$	h	h_1	h	h		
	2	TLSR/L-82V	.125	.500	.750	.500	.500	3.500	.880	TLG 2	
		TLSR/L-102	.125	.625	.875	.625	.625	4.500	.880	TLG 2	
		TLSR/L-122B	.125	.750	1.000	.750	.750	4.500	.880	TLG 2	
		TLSR/L-162C	.125	1.000	1.250	1.000	1.000	5.000	1.300	TLG 2	
		TLSR 62D-S	.125	.375	.375	.375	.375	6.000	.880	TLG 2	
		TLSR 82D-S	.125	.500	.500	.500	.500	6.000	.880	TLG 2	
			TLSR 102D-S	.125	.625	.625	.625	.625	6.000	.880	TLG 2
		3	TLSR/L-123B	.180	.750	1.000	.750	.750	4.500	1.300	TLG 3
			TLSR/L-163C	.180	1.000	1.250	1.000	1.000	5.000	1.300	TLG 3
			TLSR/L-163D	.180	1.000	1.250	1.000	1.000	6.000	1.300	TLG 3
			TLSR/L-203D	.180	1.250	1.500	1.250	1.250	6.000	1.300	TLG 3
			TLSR 83D-S	.180	.500	.500	.500	.500	6.000	.880	TLG 3
			TLSR 103D-S	.180	.625	.625	.625	.625	6.000	.880	TLG 3
			TLSR 123D-S	.180	.750	.750	.750	.750	6.000	1.300	TLG 3
		4	TLSR/L-164C	.280	1.000	1.250	1.000	1.000	5.000	1.400	TLG 4
			TLSR/L-164D	.280	1.000	1.250	1.000	1.000	6.000	1.400	TLG 4
	TLSR/L-204D		.280	1.250	1.500	1.250	1.250	6.000	1.400	TLG 4	

¹⁾ f_1 dimension qualified over sharp point of insert.

R = Right hand, L = Left hand

Main spare parts

		Clamp			
Tool type	Insert size	Right hand	Left hand	Clamping screw (thread)	Key (inch)
TLSR/L	2	C2R	C2L	10440 (6-32)	3021 011-764 (⁷ / ₆₄)
	3	C3R	C3L	10090 (10-32)	3021 010-040 (⁵ / ₃₂)
	4	C4R	C4L	10090 (10-32)	3021 010-040 (⁵ / ₃₂)

Shank tools

Clamp design

TLER/L

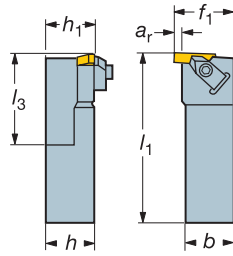

Right hand tools use left hand inserts.

Left hand tools use right hand inserts

Right hand style shown

Main application	Insert size	Ordering code	Dimensions							Gauge inserts
			a	b	$f_1^{1)}$	h	h_1	h	b	
	2	TLER/L-82V	.125	.500	.750	.500	.500	3.500	1.000	TLG 2
		TLER-122B	.125	.750	1.000	.750	.750	4.500	1.000	TLG 2
		TLER-162C	.125	1.000	1.250	1.000	1.000	5.000	1.000	TLG 2
	3	TLER/L-163C	.180	1.000	1.250	1.000	1.000	5.000	2.000	TLG 3
		TLER/L-163D	.180	1.000	1.250	1.000	1.000	6.000	2.000	TLG 3
		TLER-203D	.180	1.250	1.500	1.250	1.250	6.000	2.000	TLG 3
4	TLER/L-164D	.280	1.000	1.375	1.000	1.000	6.000	2.000	TLG 4	

1) f_1 dimension qualified over sharp point of insert.

R = Right hand, L = Left hand

Main spare parts

Tool type	Insert size	Clamp		Clamping screw (thread)	Key (inch)
		Right hand	Left hand		
TLER/L	2	C2L	C2R	10440 (6-32)	3021 011-764 ($7/64$)
	3	C3L	C3R	10090 (10-32)	3021 010-040 ($5/32$)
	4	C4L	C4R	10090 (10-32)	3021 010-040 ($5/32$)

Coromant Capto® cutting units

Clamp design

Cx-CTLHOR/L

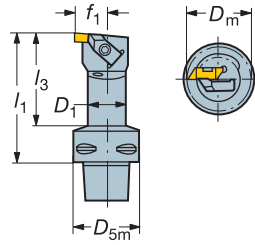

Right hand tools use left hand inserts.

Left hand tools use right hand inserts

Right hand style shown

Main application	Insert size	Ordering code	Dimensions						Gauge inserts
			D_1	D_{5m}	$D_m \text{ min}$	f_1	l_1	l_3	
	3	C4-CTLHOR/L-17070-3	1.000	1.575	1.260	.669	2.756	1.886	TLG 3
		C5-CTLHOR/L-22090-3	1.250	1.969	1.580	.866	3.500	2.680	TLG 3
		C6-CTLHOL-27140-3	1.750	2.480	2.130	1.063	5.512	4.547	TLG 3
	4	C5-CTLHOL-24140-4	1.250	1.969	1.580	.945	5.512	4.626	TLG 4

R = Right hand, L = Left hand

Main spare parts

Tool type	Insert size	Clamp		Clamping screw (thread)	Key (inch)
		Right hand	Left hand		
Cx-CTLHOR/L	3	C3L	C3R	10090 (10-32)	3021 010-040 (⁵ / ₃₂)
	4	C4L	C4R	10090 (10-32)	3021 010-040 (⁵ / ₃₂)

Steel shank boring bars

Clamp design

SI-CTLHOR/L

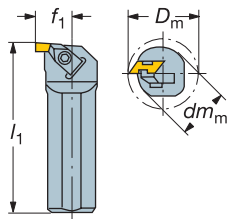

Right hand tools use left hand inserts.

Left hand tools use right hand inserts

Right hand style shown

Main application	Insert size	Ordering code	Dimensions				Gauge inserts
			dm_m	D_m min	f_1	h	
	2	SI-CTLHOR/L-05102	.625	1.000	.500	10.000	TLG 2
		SI-CTLHOR/L-06102	.750	1.130	.562	10.000	TLG 2
		SI-CTLHOR/L-08122	1.000	1.380	.688	12.000	TLG 2
	3	SI-CTLHOR/L-08123	1.000	1.380	.688	12.000	TLG 3
		SI-CTLHOR/L-10143	1.250	1.750	.875	14.000	TLG 3
		SI-CTLHOR/L-12143	1.500	2.000	1.000	14.000	TLG 3
		SI-CTLHOR/L-16163	2.000	2.500	1.250	16.000	TLG 3
	4	SI-CTLHOR/L-14143	1.750	2.250	1.125	14.000	TLG 3
		SI-CTLHOR/L-14144	1.750	2.500	1.250	14.000	TLG 4
		SI-CTLHOR-16164	2.000	2.750	1.375	16.000	TLG 4

R = Right hand, L = Left hand

Main spare parts

Tool type	Insert size	Clamp		Clamping screw (thread)	Key (inch)
		Right hand	Left hand		
SI-CTLHOR/L	2	C2L	C2R	10440 (6-32)	3021 011-764 (⁷ / ₆₄)
	3	C3L	C3R	10090 (10-32)	3021 010-040 (⁵ / ₃₂)
	4	C4L	C4R	10090 (10-32)	3021 010-040 (⁵ / ₃₂)

Grooving head with CoroTurn® SL Coupling

Clamp design

570C-TLER/L

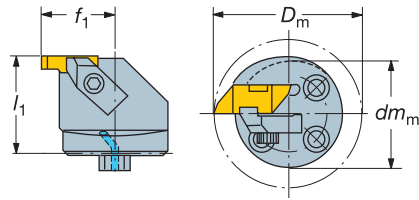

Right hand tools use left hand inserts.

Left hand tools use right hand inserts

Right hand style shown

Main application	Insert size	Ordering code	Dimensions				Gauge inserts	
			Coupling size, mm	dm_m	D_m min	f_1		l_1
	2	570C-TLER-20-2	20	.790	1.340	.669	.984	TLG 2
		570C-TLER-25-2	25	.980	1.340	.669	.984	TLG 2
	3	570C-TLER/L-32-3	32	1.260	1.730	.866	1.340	TLG 3
		570C-TLER-40-3	40	1.580	2.210	1.102	1.575	TLG 3
4	570C-TLER-40-4	40	1.580	2.210	1.102	1.575	TLG 4	

R = Right hand, L = Left hand

Main spare parts

		Clamp			
Tool type	Insert size	Right hand	Left hand	Clamping screw (thread)	Key (inch)
TLER/L	2	C2L	C2R	10440 (6-32)	3021 011-764 ($7/64$)
	3	C3L	C3R	10090 (10-32)	3021 010-040 ($5/32$)
	4	C4L	C4R	10090 (10-32)	3021 010-040 ($5/32$)

Bear Paw inserts

For external grooving

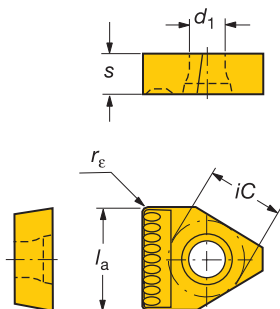
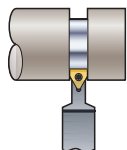

For ISO application areas, see bottom of the page.

	<i>iC</i>	Ordering code	Dimensions						ISO		
			<i>l_a</i> inch	<i>l_a</i> mm	<i>d₁</i>	<i>s</i>	<i>r_ε</i> inch	<i>r_ε</i> mm	P	M	S
 BP	.375	BP-500030	.500	12.7	.173	.188	.030	0.76	GC	GC	GC
	.500	BP 625030	.625	15.88	.173	.188	.030	0.76	★	★	★
	.625	BP-750030	.750	19.05	.216	.250	.030	0.76	★	★	★
									P45	M35	S30

★ = First choice

Double ended grooving blade

Screw clamp

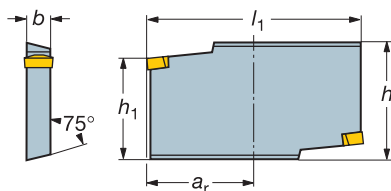

Right hand blade shown.

For tool blocks, see page .

Main application	Cutting edge height, mm	<i>iC</i>	<i>a</i> max	Ordering code	Dimensions				Gauge inserts
					<i>b</i>	<i>h</i>	<i>h₁</i>	<i>h</i>	
	45	.375	3.937	BPR/L151.2-45 500	.435	2.067	1.772	10.236	BP 500030

R = Right hand, L = Left hand

Main spare parts

Blade	Insert screw	Key (Torx Plus)
BPR/L 151.2-45	5513 020-29	5680 043-13 (9IP)

Bear Paw

Shank tools for grooving

Screw design

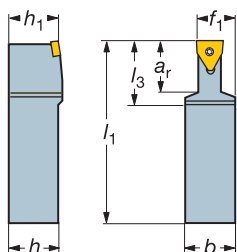

Neutral style

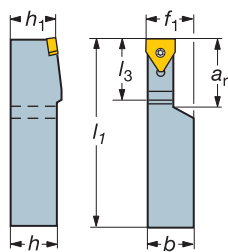

Right hand style

Main application	iC	a max	Ordering code	Dimensions						Gauge inserts
				b	f ₁	h	h ₁	l ₁	l ₃	
	.375	1.120	BPGN 50020	1.250	.875	1.250	1.250	6.000	1.380	BP 500030
	.500	1.380	BPGN 62520	1.250	.937	1.250	1.250	6.000	1.630	BP 625030
	.625	1.630	BPGN 75024	1.500	1.125	1.500	1.500	7.500	1.870	BP 750030
	.375	1.250	BPGR/L 50024	1.500	1.500	1.500	1.500	6.000	1.140	BP 500030
	.500	1.500	BPGR/L 62524	1.500	1.500	1.500	1.500	6.000	1.420	BP 625030
	.625	1.750	BPGR/L 75024	1.500	1.500	1.500	1.500	7.000	1.650	BP 750030

N = Neutral, R = Right hand, L = Left hand

Main spare parts

Shank tool	Insert screw	Key (Torx Plus)
BP-500030	5513 020-29	5680 049-01 (15IP)
BP-625030	5513 020-29	5680 049-01 (15IP)
BP-750030	5513 020-26	5680 043-14 (20IP)

Tool block for parting blades

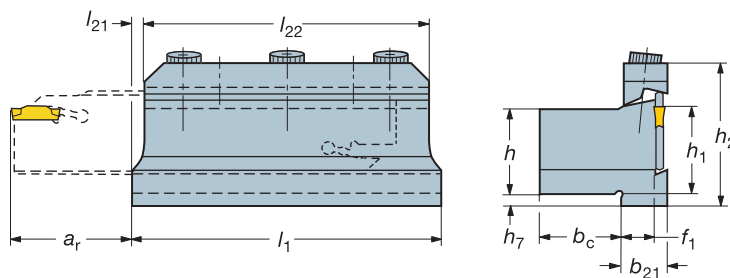

Metric version

Cutting edge height on blades, mm	ar max	Ordering code	Dimensions									
			b21	bc	f1	h	h1	h2	h7	l1	b21	l22
45	100	151.2-3232-45	20.4	31.6	13.4	32	32	82.5	29.7	160	5	150
45	100	151.2-4040-45	20.4	39.6	13.4	40	40	82.5	21.7	160	5	150

Inch version

Cutting edge height on blades, mm	ar max	Ordering code	Dimensions, inch									
			b21	bc	f1	h	h1	h2	h7	l1	b21	l22
45	3.93	151.2-20-45	.800	1.230	.5299	1.250	1.250	3.250	1.181	6.299	.197	5.906
45	3.93	151.2-24-45	.800	1.480	.5299	1.500	1.500	3.250	1.929	6.299	.197	5.906

Main spare parts

Tool block		Clamp	Clamp screw	Key (mm)
mm	Inch			
151.2-3232-45	151.2-20-45	5412 120-03	3212 010-412	3021 010-060 (6.0)
151.2-4040-45	151.2-24-45	5412 120-03	3212 010-412	3021 010-060 (6.0)

Coolant adapter for tool blocks and adapters

Cutting edge height on blades, mm	Ordering code	Dimensions, mm, inch						
		b22	h21	h22	l23	l24	l25	Dth
45	5691 050-011	17	10	28	26	16.2	17.2	G¼"
		.669	.394	1.10	1.02	.638	.677	G¼"

Ordering example: 2 pieces 5691 050-011

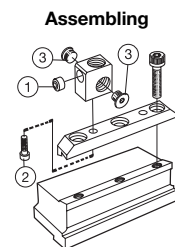

Main spare parts

1	2	3		
Nozzle	Mounting screw	Plug	Key (mm) for plug	Key (mm) for mounting screw
5691 029-02	3212 010-358	5519 055-01	3021 010-060 (6.0)	3021 010-050 (5.0)

Adapter for CoroCut® and T-Max Q-Cut® parting blades

Coromant Capto®

Radial mounting

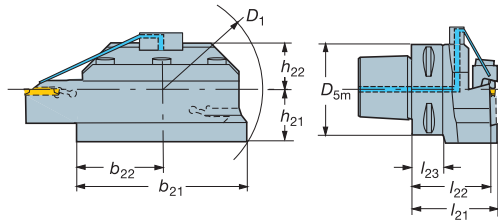
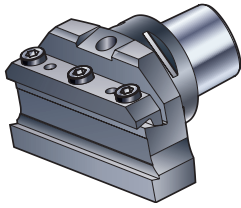

Neutral style shown

Cutting edge height, mm	Coromant Capto® size	Ordering code	Dimensions, inch									
			D_{5m}	b_{21}	b_{22}	D_1	h_{21}	h_{22}	l_{21}	l_{22}	l_{23}	
45	C6	C6-APBA-80068-45	2.480	6.299	3.150	7.795	2.835	1.654	2.677	2.382	.913	11.9
	C8	C8-APBA-80068-45	3.150	6.299	3.150	7.795	2.835	1.654	2.677	2.382	1.228	

Warning!

The adapters are designed for automatic tool change.
Make sure that there is no risk of interference in the magazine and tool changing cycle.

Coolant adapter ordered separately. See page

Main spare parts

Adapters	Screw	Clamp	Plug	Key (mm)
C6-APBA-80068-45	3212 010-412	5412 120-03	5519 055-01	3021 010-060 (6.0)
C8-APBA-80068-45	3212 010-412	5412 120-03	5519 055-01	3021 010-060 (6.0)

Top-Lok® external screw clamp tools

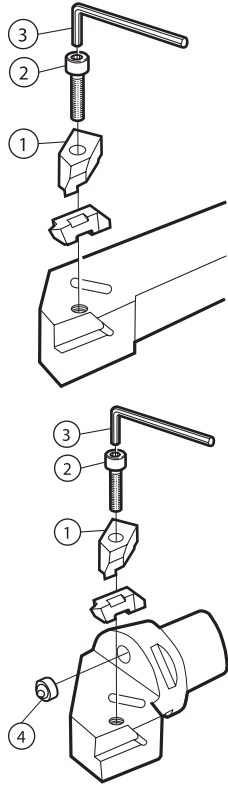

Tool type and size		1		2		3		4	
Shank holders		Clamp		Clamping screw		Key (inch)		Nozzle	
Coromant Capto®		Right hand	Left hand	Thread					
TLER/L-82V		C2L	C2R	10440		3021 011-764			
TLER/L-102B				(6-32)		(7/64)			
TLER/L-122B									
TLER/L-162C									
TLER/L-163C	C3-TLER/L-22040-3	C3L	C3R	10090		3021 010-040		5691 029-01	
TLER/L-163D	C4-TLER/L-27050-3			(10-32)		(5/32)		5691 029-01	
TLER/L-203D	C5-TLER/L-35060-3							5691 029-02	
TLER/L-243D	C6-TLER/L-45065-3							5691 029-02	
TLER/L-164D	C6-TLER/L-45065-4	C4L	C4R	10090		3021 010-040			
TLER/L-204D				(10-32)		(5/32)			
TLER/L-244D									
TLER/L-205D		C5L	C5R	10310		174.1-873			
				(5/6-18)		(1/4)			
TLRR/L-123B	C3-TLRR/L-22045-3	C3L	C3R	10090		3021 010-040		5691 032-01	
TLRR/L-163D	C4-TLRR/L-27050-3			(10-32)		(5/32)		5691 032-02	
TLRR/L-203D	C5-TLRR/L-35060-3							5691 032-02	
TLRR/L-243D	C6-TLRR/L-45065-3							5691 032-02	
TLSR/L-82V	C3-TLSR/L-22040-2	C2R	C2L	10440		3021 010-764		5691 032-01	
TLSR/L-102	C4-TLSR/L-27050-2			(6-32)		(7/64)		5691 032-02	
TLSR/L-122B									
TLSR/L-162C									
TLSR/L-123B	C3-TLSR/L-22045-3	C3R	C3L	10090		3021 010-040		5691 032-01	
TLSR/L-163C	C4-TLSR/L-27050-3			(10-32)		(5/32)		5691 032-02	
TLSR/L-163D	C5-TLSR/L-35060-3							5691 032-02	
TLSR/L-203D	C6-TLSR/L-45065-3							5691 032-02	
TLSR/L-243D									
TLSR/L-164C	C4-TLSR/L-27055-4	C4R	C4L	10090		3021 010-040		5691 032-02	
TLSR/L-164D	C5-TLSR/L-35060-4			(10-32)		(5/32)		5691 032-02	
TLSR/L-204D	C6-TLSR/L-45065-4							5691 032-02	
TLSR/L-244E									
TLSR/L-205D		C5R	C5L	10310		174.1-873			
TLSR/L-245D				(5/16-18)		(1/4)			
	C5-TLSR/L-35060-6	C6R	C6L	10090		3021 010-040		5691 032-02	
	C6-TLSR/L-45065-6			(10-32)		(5/32)		5691 032-02	

Top-Lok® internal screw clamp tools

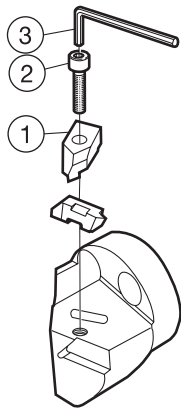
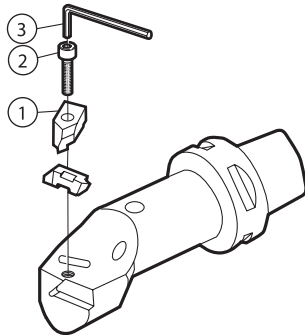
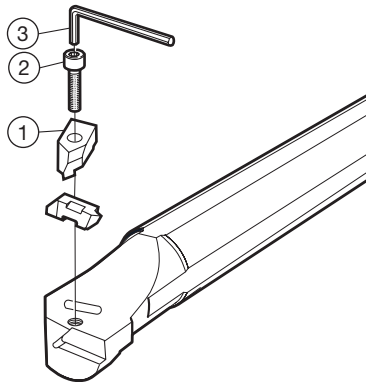

Tool type and size		1	2	3
Coromant Capto®		Clamp		Clamping screw
Shank holders		Right hand	Left hand	Thread
C-CTLHOR/L-05102		C2L	C2R	10440
C-CTLHOR/L-06102				(6-32)
C-CTLHOR/L-08123		C3L	C3R	10090
				(10-32)
SI-CLHOR/L-05102	C3-CTLHOR/L-13060-2	C2L	C2R	10440
SI-CTLHOR/L-06102				(6-32)
SI-CTLHOR/L-08123	C3-CTLHOR/L-17060-3	C3L	C3R	10090
SI-CTLHOR/L-10143	C4-CTLHOR/L-17070-3			(10-32)
SI-CTLHOR/L-12143	C5-CTLHOR/L-22090-3			
SI-CTLHOR/L-14143	C6-CTLHOR/L-27140-3			
SI-CTLHOR/L-16143	C6-CTLHOR/L-32150-3			
SI-CTLHOR/L-20143				
SI-CTLHOR/L-14144	C5-CTLHOR/L-24140-4	C4L	C4R	10090
SI-CTLHOR/L-16164	C6-CTLHOR/L-27140-4			(10-32)
SI-CTLHOR/L-18164	C6-CTLHOR/L-32150-4			
SI-CTLHOR/L-20164				
SI-CTLHOR/L-16165		C5L	C5R	10310
SI-CTLHOR/L-20165				(5/16-18)
SI-CTLHOR/L-16166		C6L	C6R	10090
SI-CTLHOR/L-20166				(10-32)
	C3-CTLSOR/L-17060-3	C3L	C3R	10090
	C4-CTLSOR/L-17070-3			(10-32)
	C5-CTLSOR/L-22090-3			
	C6-CTLSOR/L-27140-3			
				174.1-873
				(1/4)
				3021 010-040
				(5/32)
				3021 010-040
				(5/32)

Tool type and size		1	2	3
Shank holders		Clamp		Clamping screw
		Right hand	Left hand	Thread
570C-TLER/L-20-2		C2L	C2R	10440
570C-TLER/L-25-2				(6-32)
570C-TLER/L-32-2		C3L	C3R	10090
570C-TLER/L-40-3				(10-32)
570C-TLER/L-50-3				
570C-TLER/L-60-3				
570C-TLER/L-40-4		C4L	C4R	10090
570C-TLER/L-50-4				(10-32)
570C-TLER/L-60-4				
570C-TLER/L-40-6		C6L	C6R	10090
570C-TLER/L-50-6				(10-32)
570C-TLER/L-60-6				
				3021 011-764
				(7/64)
				3021 010-040
				(5/32)
				3021 010-040
				(5/32)

Bear Paw blade and shank tools

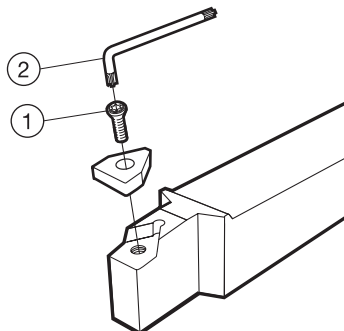

Tool type	1	2
BPR/L 151.2-45-500	Insert screw	Key (Torx Plus)
BPGN-50020	5513 020-29	5680 043-13 (15IP)
BPGN-62520	5513 020-29	5680 049-01 (15IP)
BPGN-75024	5513 020-29	5680 049-01 (15IP)
BPGR/L-50024	5513 020-26	5680 043-14 (30IP)
BPGR/L-62524	5513 020-29	5680 049-01 (15IP)
BPGR/L-75024	5513 020-29	5680 049-01 (15IP)
	5513 020-26	5680 043-14 (20IP)

Tool block for parting blades

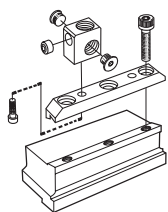
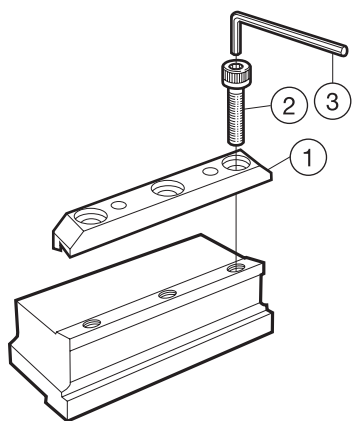

Tool block		1	2	3
Metric	Inch	Clamp	Clamp screw	Key (mm)
151.2-3232-45	151.2-20-45	5412 120-03	3212 010-412	3021 010-060 (6.0)
151.2-4040-45	151.2-24-45	5412 120-03	3212 010-412	3021 010-060 (6.0)

Coolant adapter

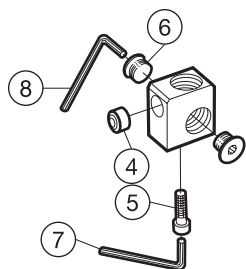

4	5	6	7	8
Nozzle	Mounting screw	Plug	Key (mm) for mounting screw	Key (mm) for plug
5691 029-02	3212 010-358	5519 055-01	3021 010-050 (5.0)	3021 010-060 (6.0)

Adapter for CoroCut® and T-Max Q-Cut® parting blades

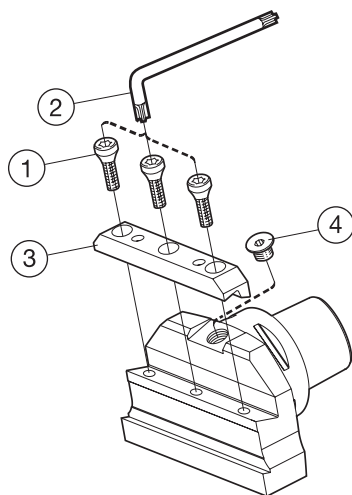

	1	2	3	4	
Adapter	Screw	Key (mm)	Clamp	Plug	Optional coolant adapter
C6-APBA-80068-45	3212 010-412	3021 010-060 (6.0)	5412 120-03	5519 055-01	5691 050-011
C8-APBA-80068-45	3212 010-412	3021 010-060 (6.0)	5412 120-03	5519 055-01	5691 050-011



- Quick quotation
- Easy to order
- Competitive delivery

Even more possibilities with tailored design!

If you do not find what you need in our comprehensive standard program, choose the tool shape you require and we will tailor it for you to *your* dimensions.

Top-Lok inserts

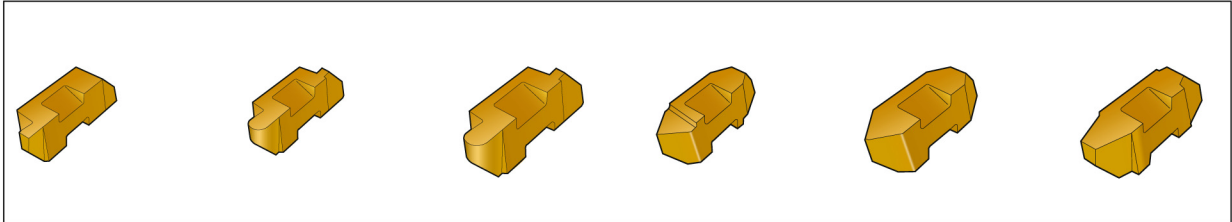

Top-Lok inserts for grooving operations

Tailor Made widths, front angles and radii options

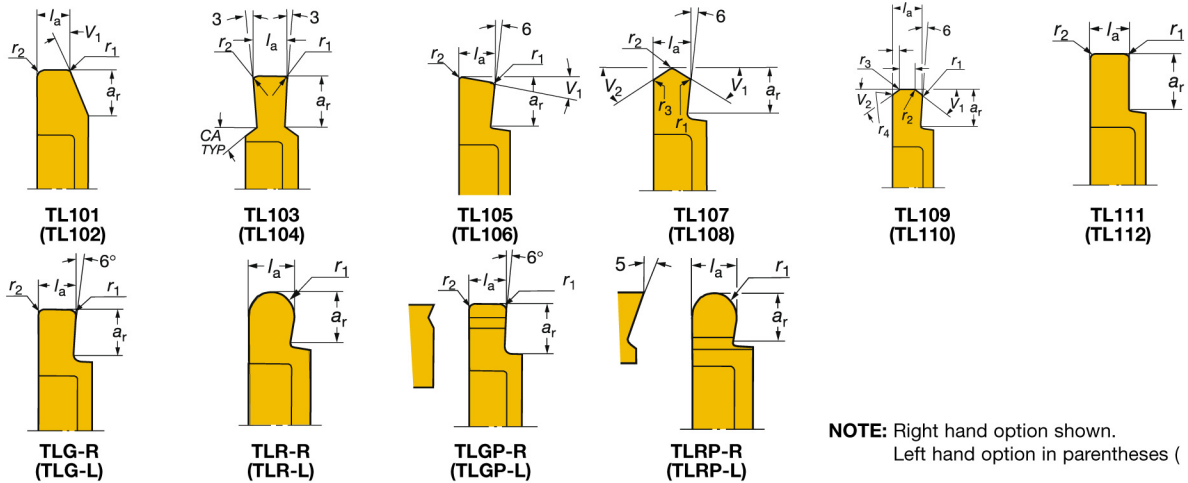

NOTE: Right hand option shown. Left hand option in parentheses ().

Top-Lok inserts for threading operations

Tailor Made Acme threads

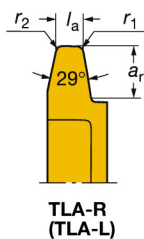

TLA-R (TLA-L)

Tailor Made 60° threading inserts

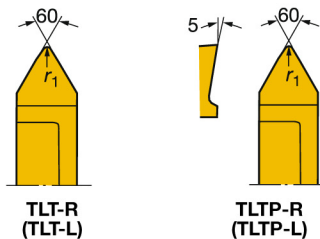

TLT-R (TLT-L)

TLTP-R (TLTP-L)

Top-Lok inserts for facegrooving

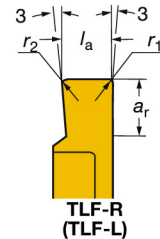

TLF-R (TLF-L)

Options

Note! For specific details regarding the options, contact your Sandvik Coromant sales representative.

Sizes 2, 3, 4

	#2	#3	#4
a_r Max	.110"	.220"	.280"
	#2	#3	#4
TLF only	.110"	.150"	.250"

Grades GC2135, GC4125, GC1015, H10F, H13A, GC3020

		Top-Lok inserts		Inquiry/ordering No.																																												
		Company		Distributor or Sandvik Coromant Representative																																												
		Attention		Attention																																												
		Street		Street																																												
		City, State, Zip	Fax #	City, State, Zip Fax #																																												
Quantity	Customer Marking																																															
State nearest standard catalog code, see turning catalog																																																
			Inch std	Your value/ Your choice																																												
State only your options deviating from the above standard																																																
Option No	Right hand option = TL101, TL103, TL105, TL107, TL109, TL111, TLG-R, TLR-R, TLGP-R, TLRP-R TLA-R, TLT-R, TLTP-R, TLF-R Left hand option = TL102, TL104, TL106, TL108, TL110, TL112, TLG-L, TLR-L, TLGP-L, TLRP-L TLA-L, TLT-L, TLTP-L, TLF-L			 <input style="width: 80px; height: 20px;" type="text"/>																																												
Insert seat size	2, 3, 4			<input style="width: 80px; height: 20px;" type="text"/>																																												
Insert grade	GC2135, GC4125, GC1015, H10F, H13A, GC3020			<input style="width: 80px; height: 20px;" type="text"/>																																												
Cutting depth a_r	<table border="1" style="width: 100%; border-collapse: collapse; font-size: small;"> <thead> <tr> <th>insert size</th> <th>2</th> <th>3</th> <th>4</th> </tr> </thead> <tbody> <tr> <td>OPTIONS</td> <td colspan="3" style="text-align: center;">a_r max</td> </tr> <tr> <td>TL</td> <td>.110</td> <td>.220</td> <td>280</td> </tr> <tr> <td>TLG</td> <td>.110</td> <td>.220</td> <td>280</td> </tr> <tr> <td>TLR</td> <td>.110</td> <td>.220</td> <td>280</td> </tr> <tr> <td>TLGP</td> <td>.110</td> <td>.220</td> <td>280</td> </tr> <tr> <td>TLRP</td> <td>.110</td> <td>.220</td> <td>280</td> </tr> <tr> <td>TLA</td> <td>.110</td> <td>.220</td> <td>280</td> </tr> <tr> <td>TLT</td> <td>.110</td> <td>.220</td> <td>280</td> </tr> <tr> <td>TLTP</td> <td>.110</td> <td>.220</td> <td>280</td> </tr> <tr> <td>TLF</td> <td>.110</td> <td>.150</td> <td>.250</td> </tr> </tbody> </table>			insert size	2	3	4	OPTIONS	a_r max			TL	.110	.220	280	TLG	.110	.220	280	TLR	.110	.220	280	TLGP	.110	.220	280	TLRP	.110	.220	280	TLA	.110	.220	280	TLT	.110	.220	280	TLTP	.110	.220	280	TLF	.110	.150	.250	<input style="width: 80px; height: 20px;" type="text"/>
insert size	2	3	4																																													
OPTIONS	a_r max																																															
TL	.110	.220	280																																													
TLG	.110	.220	280																																													
TLR	.110	.220	280																																													
TLGP	.110	.220	280																																													
TLRP	.110	.220	280																																													
TLA	.110	.220	280																																													
TLT	.110	.220	280																																													
TLTP	.110	.220	280																																													
TLF	.110	.150	.250																																													

The value/choice must be given

If no value/choice is specified, it will be recommended by the system

Grades for parting and grooving



Steel, cast steel, long chipping malleable iron

Basic grades

GC3020 (HC) – P15 (P05 – P25)

A very high wear resistant CVD coated grade. Especially recommended for grooving and turning in stable conditions. Due to its excellent hot hardness, also effective in hard steels. To be used at high cutting speeds under good conditions.

GC1125 (HC) - P30 (P15-P45)

An excellent general purpose grade. First choice for parting off tubes in steel. Also very good in grooving and turning operations. This new PVD coated grade works very well in low carbon steel and other smearing materials. Speeds and feeds from medium to low.

GC2135 (HC) – P35 (P20-P50)

A CVD coated carbide grade for toughness demanding operations such as cut-off to center and interrupted cuts. Backup alternative when grooving and turning. Very good bulk and edgeline toughness. To be used at low to medium cutting speeds.

Complementary grades

GC235 (HC) – P45 (P25-P50)

Parting and grooving of steel in operations requiring toughness. Suitable for low speeds and under unfavorable conditions.



Cast iron, chilled cast iron, short chipping malleable iron.

Basic grades

GC1125 (HC) - K30 (K15-K35)

A new PVD coated all-purpose grade for toughness demanding operations and interrupted cuts. To be used at medium to low cutting speeds.

Complementary grades

GC3020 (HC) – K15 (K05-K25)

A very high wear resistant CVD coated grade for high cutting speeds in grooving and turning under good conditions. Due to its excellent hot hardness, also effective on hard cast iron.

H13A (HW) – K20 (K10-K30)

Good abrasive wear resistance and toughness for parting/grooving of cast iron.



Austenitic/ferritic/martensitic stainless steel, cast steel, manganese steel, alloy cast iron, malleable iron, free cutting steel.

Basic grades

GC1125 (HC) - M25 (M15-M35)

An excellent general purpose PVD coated grade with a combination of high wear resistance and good edge security for stainless steels. First choice for grooving and turning operations. Also good for parting off, especially tubes. Medium to low cutting speeds and feeds from medium to low.

GC2135 (HC) – M30 (M20-M40)

First choice CVD coated carbide grade for parting off in stainless steel and other toughness demanding operations. Very good bulk and edgeline toughness. To be used at medium to low cutting speeds.

Complementary grades

H13A (HW) – M15 (M10-M30)

Combines good abrasive wear resistance and toughness for grooving of heat resistant steels and titanium alloys.

GC235 (HC) – M35 (M25-M40)

Parting and grooving of stainless steels where toughness is required. Use at low speeds and under unfavorable conditions.



Non-ferrous metals

Basic grades

H13A (HW) – N20 (N10-N30)

Uncoated carbide grade. Combines good abrasive wear resistance and toughness for parting and grooving of aluminum alloys.



Heat resistant super alloys

Basic grades

H13A (HW) – S15 (S10-S30)

Uncoated carbide grade. Combines good abrasive wear resistance and toughness for parting and grooving. First choice in titanium.

GC1125 (HC) - S25 (S15-S35)

A PVD coated grade for toughness demanding operations. First choice for interrupted cuts. To be used at low cutting speeds.

Complementary grades

GC235 (HC) – S30 (S25-S40)

A CVD coated carbide grade for parting and grooving of heat resistant super alloys. Use at low cutting speeds.

Safety information in connection with grinding of cemented carbide

Material composition

Hard metal products contain tungsten carbide and cobalt. Other substances may contain titanium carbide, tantalum carbide, niobium carbide, chromium carbide, molybdenum carbide or vanadium carbide. Some grades contain titanium carbide nitride and/or nickel.

Routes of exposure

Grinding or heating of hard metal blanks or hard metal products will produce dust or fumes with dangerous ingredients that can be inhaled, swallowed or come in contact with the skin or eyes.

Acute toxicity

The dust is toxic by inhalation. Inhalation may cause irritation and inflammation of the airways. Significantly higher acute inhalation toxicity has been reported during simultaneous inhalation of cobalt and tungsten carbide compared to inhalation of cobalt alone.

Skin contact can cause irritation and rash. Personnel whose skin is sensitive may experience an allergic reaction.

Chronic toxicity

Repeated inhalation of aerosols containing cobalt may cause obstruction in the airways. Prolonged inhalation of increased concentrations may cause lung fibrosis or lung cancer. Epidemiological studies indicate that workers exposed in the past to high concentrations of tungsten carbide/cobalt carried an increased risk of developing lung cancer.

Cobalt and nickel are potent skin sensitizers. Repeated or prolonged contact can cause irritation.

Risk phrases

Toxic: danger of serious damage to health by prolonged exposure through inhalation

Toxic by inhalation

Limited evidence of a carcinogenic effect.

May cause sensitization by inhalation and skin contact

Preventive measures

Avoid formation and inhalation of dust. Use adequate local exhaust ventilation to keep personal exposure well below the nationally authorised limits.

- If ventilation is not available or adequate, use respirators nationally approved for the purpose.
- Use safety goggles or glasses with side shields when necessary.
- Avoid repeated skin contact. Wear suitable gloves. Wash skin thoroughly after handling.
- Use suitable protective clothing. Launder clothing as needed.
- Do not eat, drink or smoke in the working area. Wash skin thoroughly before eating, drinking or smoking.

For the sake of the environment

Get into the Coromant Recycling Concept (CRC) now!

The Coromant Recycling Concept (CRC) is a comprehensive service for used carbide inserts (including CBN and PCD if "carrier" is cemented carbide) and solid carbide tools offered by Sandvik Coromant to all its customers.

In the light of increasing consumption of non-renewable raw materials, the economic management of dwindling resources is a duty owed by all manufacturers.

Sandvik Coromant is playing its part by offering to collect used carbide inserts and solid carbide tools and recycle them in the most environmentally friendly way.

All used hard-metal inserts are collected in the collection box at the workplace.

When the collection box is sufficiently full, its contents are transferred to the transport box. The full transport box is then sent to the nearest Sandvik Coromant office or to your Coromant dealer who can also give you more information.

The benefits of the CRC speak for themselves

- A one-stop worldwide recycling system.
- For direct and trade customers.
- Simple procedure with collection and transport boxes.
- Less waste, easing the burden on the environment.
- Better utilisation of resources.
- Other manufacturers' carbide inserts are also accepted.



Order collection boxes for each lathe, milling machine, drill or for your machining center. We recommend one collection box for inserts and one separate box for solid carbide tools for each cutting workplace.

Collection box (yellow):	Order numbers
Transport box for solid carbide tools (wooden):	91617
Transport box inserts (wooden):	92994
	92995



Local support is just a click away

www.sandvik.coromant.com

Your local Sandvik Coromant distributor:

Phone: 1 800-SANDVIK
E-mail: us.coromant@sandvik.com

LIT-CAT-TOPILOK 11 © AB Sandvik Coromant 2011



Your success in focus