

MULTI-TASK MACHINING

Tooling possibilities

H2

Products

Tool holder overview

H7

Coromant Capto® multifunctional tools

CoroPlex™ MT - milling and turning tool

H4

CoroPlex™ TT - turning tool

H9

CoroPlex™ SL mini-turret

H14

CoroTurn® HP - Coromant Capto® tools for High Pressure coolant

H21

T-Max® P - holders for negative basic-shape inserts

H22

CoroTurn® 107 - holders for positive basic-shape inserts

H25

Coromant Capto® tools for general turning

CoroTurn® RC - holders for negative basic-shape inserts

H15

CoroTurn® 107 - holders for positive basic-shape inserts

H17

CoroTurn® TR - Coromant Capto® tools for copy machining

CoroTurn® TR - holders for positive basic-shape inserts

H19

Adaptors

CoroTurn® SL adaptor for cutting heads

H26

CoroTurn® SL70 adaptor for cutting heads

H27

Adaptor for shank tool - radial mounting

H28

Adaptor for shank tool - axial mounting

H29

Mini-turret for shank tool - axial mounting

H31

Adaptor for shank tool - angular mounting

H30

Boring bar adaptor

H37

Multi-task machining - tooling possibilities

Coromant Capto® – the connecting link to multi-task machining

A tooling system for multi-task machines has to transmit satisfactory torque levels, be capable of high spindle speeds, have high bending strength and have high precision couplings for repeatability accuracy with pre-measurement or setting outside the machine.

Coromant Capto® has a proven record of fulfilling all the requirements for the large variation of operational demands in these machines involving stationary and rotating tools. With its broad programme of turning, milling and drilling tools, using the same self-centering tool-coupling for a very broad application area, the system has been successfully equipped in all the major multi-task machines.

CoroPlex™ – Innovative multifunctional tools

For getting advantage of versatile multi-task machine tools and to optimize their efficiency, there is now a demand for running them with dedicated tooling. The CoroPlex™ tools are invented for multi-task machining giving:

- accessibility, stability and higher productivity
- reduced tool changing time
- saved tool pocket in tool magazine
- cost reduction - one tool replace many tools

CoroPlex™ MT – one milling and four turning tools in one

CoroPlex™ MT is a combination of two winning concepts in one – CoroMill® 390 and CoroTurn® 107. It is either applied rotating as an effective tool for milling applications – or indexed in a number of optional positions for stationary turning, external and internal, using two different CoroTurn® 107 inserts. See page A9. For ordering CoroMill 390 inserts, see chapter D, Milling.



Clamping units for turning

Standard turret heads for lathes can easily be converted to Coromant Capto® modular quick-change system by using standard clamping units. See page G6.

CoroPlex™ TT twin tools – two turning tools in one

CoroPlex™ TT twin tool is a rational solution with two turning inserts in one holder allowing for the quick changing of tooling operations by a quick indexing of the tool.



CoroPlex™ SL mini-turret – four turning tools in one

Build your own multi-functional tool by using Coromant Capto® tool adaptor and apply a CoroPlex™ SL mini turret adaptor plate to be combined with four SL cutting heads and blades for turning, threading or grooving operations. See page G6.

Multi-task machining - tooling possibilities

Turning tools

For general turning the T-Max P system with negative inserts and CoroTurn® 107 with positive inserts form the basis for high productivity turning. In parting and grooving the first choice is the CoroCut® system and in threading the best option is the CoroThread® 266 or T-Max U-Lock® system. See chapters A, B and C.



Milling tools

In the CoroMill® family there is always a milling cutter to fit your needs perfectly. The CoroMill® family is a multi-purpose milling system for use in applications such as face, shoulder, slot and profile milling. See chapter D, Milling.

Holemaking tools

The drilling and boring programme, CoroDrill® and CoroBore®, offers a wide range of high performance holemaking products. Regardless of the hole style – we can offer you the right tool for the best productivity in a wide diameter range. See chapter E, Drilling and Boring.



Tool holders and tool adaptors

Modern machines and tools put greater demands on tool holders. Low run-out is required to achieve long tool life. Hydro-Grip® fulfill all the demands on a tool holder. Different types of tool adaptors are available to help in building a correct tool length. See chapter G, Tooling systems in this catalogue and Tooling systems in main catalogue for rotating tools.

Accessories

Sandvik Coromant offers a range of accessory tools for the various coupling sizes, which are strongly recommended for setting important parameters such as spindle orientation, clamping forces etc. See chapter G, Tooling systems in this catalogue and Tooling systems in main catalogue for rotating tools.



CoroPlex™ MT

Multifunctional milling and turning tool

Many optimized tools in one solution dedicated for multi-task machining.

... as a CoroMill® 390 cutter

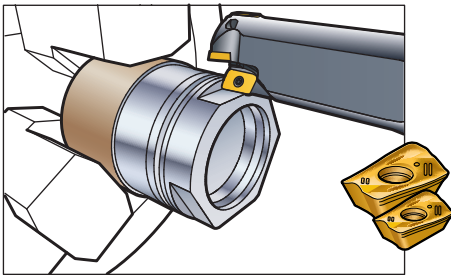

Shoulder milling

...as a CoroTurn® 107 tool

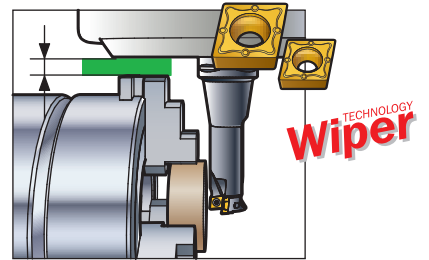

Face and longitudinal turning

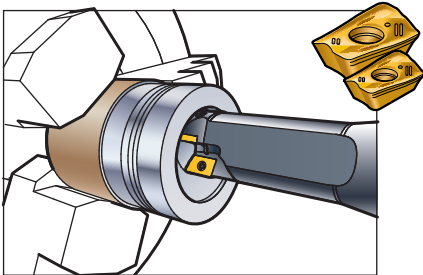
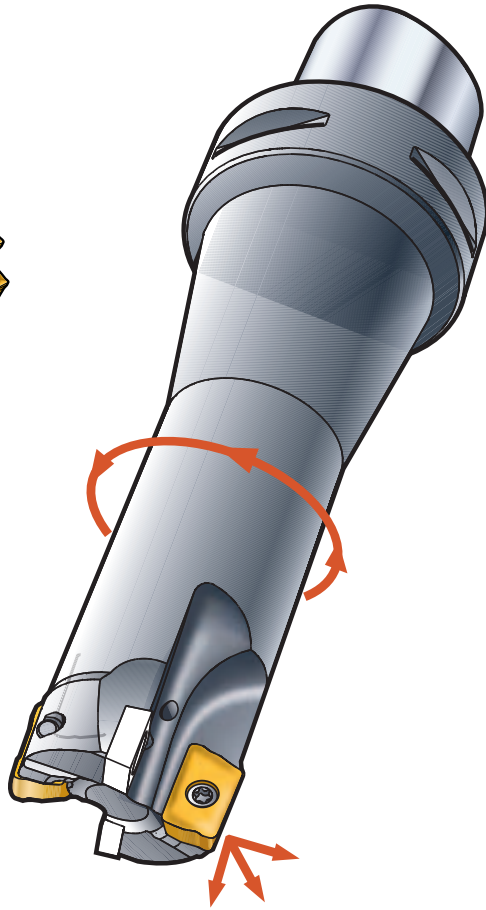

Circular interpolation in helix

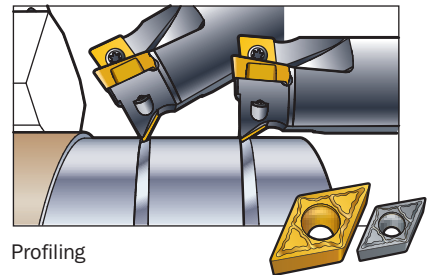

Profiling

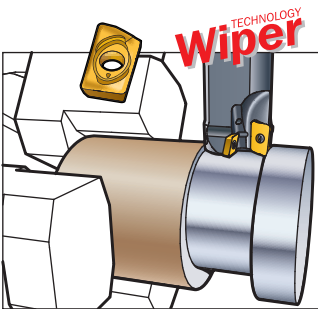

Turn milling

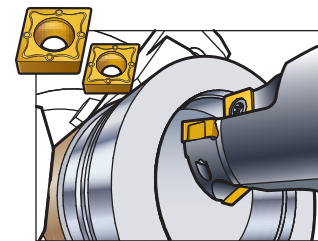

Internal turning

ISO application areas:



Multi-functional tools CoroPlex™ MT

for milling and turning in multi-task machines

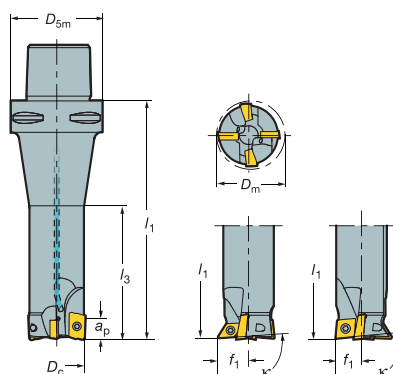
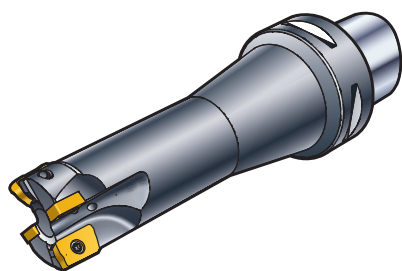

Coolant inlet: Axial through the center

Entering angle:
Lead angle:

$K_r = 93^\circ$
 -3°

$K_r = 95^\circ$
 -5°

Insert size		Coupling size	D_c mm inch	Ordering code	z_n	Dimensions, mm, inch								Gauge insert	
	iC					D_m min	D_{5m}	l_1	l_3	f_1	a_p	$\gamma^{(1)}$	$\lambda_s^{(2)}$	ISO ANSI	$n_{max}^{(3)}$
11	-	C5	32 1.260	M-32C5-39011C09D07	2	-	50 1.969	130 5.118	78.5 3.091	15.4 .394	10	-	R390-11	12000	1.0
-	09	3/8			1	35 1.378	50 1.969	129.3 5.091	77.8 3.063	15.4 .606	-	0° -5°	CCMT 09 T3 08 CCMT 3 (2.5) 2	-	
-	07	1/4			1	35 1.378	50 1.969	128.9 5.075	77.4 3.047	15.4 .606	-	0° -5°	DCMT 07 02 04 DCMT 2 (1.5) 1	-	
11	-	C6	32 1.260	M-32C6-39011C09D07	2	-	63 2.480	165 6.496	78.5 3.091	15.4 .394	10	-	R390-11	12000	1.7
-	09	3/8			1	35 1.378	63 2.480	164.3 6.469	77.8 3.063	15.4 .606	-	0° -5°	CCMT 09 T3 08 CCMT 3 (2.5)	-	
-	07	1/4			1	35 1.378	63 2.480	163.9 6.453	77.4 3.047	15.4 .606	-	0° -5°	DCMT 07 02 04 DCMT 2 (1.5) 1	-	
18	-	C6	40 1.575	M-40C6-39018C12D11	2	-	63 2.480	165 6.496	90.1 3.547	15.4 .394	10	-	R390-18	10000	1.7
-	12	1/2			1	43 1.693	63 2.480	164.4 6.472	89.5 3.524	19.0 .748	-	0° -5°	CCMT 12 04 08 CCMT 432	-	
-	11	3/8			1	43 1.693	63 2.480	163.9 6.453	89.0 3.504	19.2 .756	-	0° -5°	DCMT 11 T3 04 DCMT 3 (2.5) 1	-	
18	-	C8	40 1.575	M-40C8-39018C12D11	2	-	80 3.150	200 7.874	90.1 3.547	15.4 .394	10	-	R390-18	10000	3.3
-	12	1/2			1	43 1.693	80 3.150	199.4 7.850	89.5 3.524	19.0 .748	-	0° -5°	CCMT 12 04 08 CCMT 432	-	
-	11	3/8			1	43 1.693	80 3.150	198.9 7.831	89.0 3.504	19.2 .756	-	0° -5°	DCMT 11 T3 04 DCMT 3 (2.5) 1	-	

1) γ = Rake angle (valid with flat insert).

2) λ_s = Angle of inclination.

3) n_{max} (max. rev/min) for holders must also be considered.

Limitation on workpiece diameter

When turning axially and using the CCMT insert, it may be that the R390 inserts, because of their position in the tool, limit the workpiece diameter. See illustration below.

For ordering CoroMill 390 inserts, see chapter D, Milling.

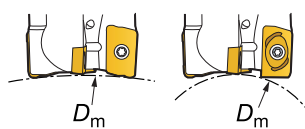

TECHNOLOGY
Wiper

Tool diameter,
 D_c mm (inch)

Max workpiece diameter, D_m mm (inch)

Insert type

	R390-11	R390-18	Wiper R390-11
32 (1.260)	150 (5.906)	-	100 (3.937)
40 (1.575)	-	380 (14.960)	-

.CMT



Multi-functional tools CoroPlex™ MT

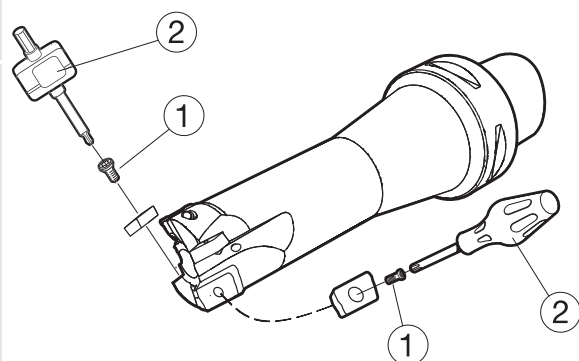

Spare parts

Insert		Torque value			
		1	2		
Type/size	ANSI-code	Insert screw	Key (Torx Plus)	Nm	ft-lbs
CCMT 09 ...	CCMT 3 (2.5)	5513 020-09	5680 046-02 (15IP)	3.0	2.2
CCMT 12 ...	CCMT 43 ...	5513 020-07	5680 046-06 (20IP)	6.4	4.7
DCMT 07 ...	DCMT 2 (1.5)	5513 020-03	5680 046-03 (7IP)	0.9	0.7
DCMT 11 ...	DCMT 3 (2.5)	5513 020-09	5680 046-02 (15IP)	3.0	2.2
R390-11 ...	R390-11 ...	5513 020-35	5680 046-01 (8IP)	1.2	0.9
R390-18 ...	R390-18 ...	5513 020-29	5680 046-02 (15IP)	3.0	2.2

One and the same tool for both rotating and stationary use

The CoroMill® 390 inserts are positioned a little ahead of the CoroTurn® inserts – axially as well as radially – to guarantee that turning inserts are not in cut when the tool is applied rotating. This means that turning of an available blind hole – using the CoroTurn® function of the tool – must be stopped before the CoroMill® 390 inserts get in contact with bottom face.

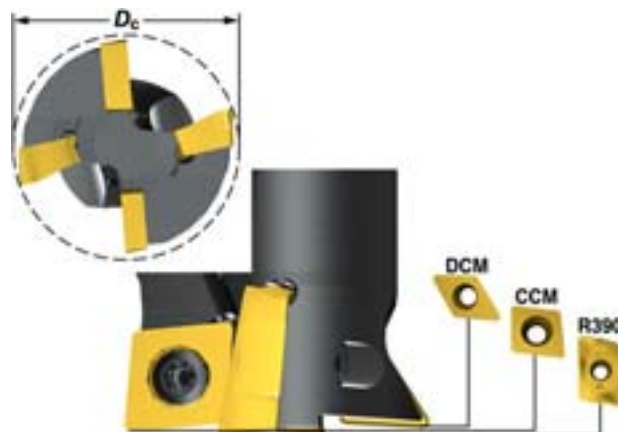











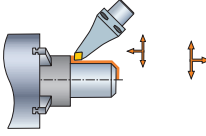
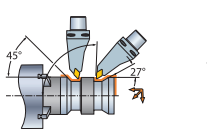
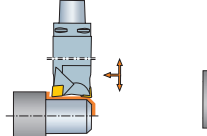

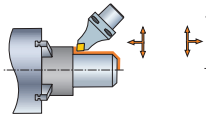
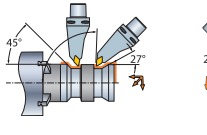
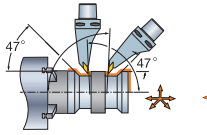

Tool length optimized for accessibility in multi-task machining

The tool bodies are extended by 65 mm (2.60 inch) compared with a corresponding conventional tools – to allow freer use of the working positions possible in multi-task machining – without any need for extensions.

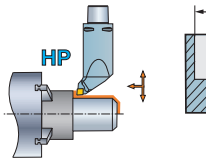
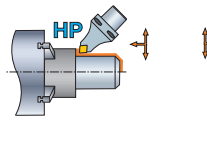
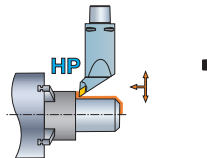
Length and design of the tool body is optimized by each Coromant Capto® size to provide best accessibility relative to the most common chuck sizes. The tool is designed with all inserts positioned on the centre line of the tool, to be easy to use together with the standard programme cycles in the machine tools.

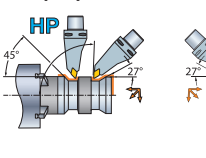
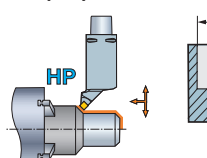
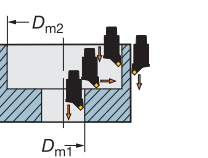

Coromant Capto® cutting units for multi-task machining

CoroPlex™ TT Twin tool, rigid clamp design	Entering angle (Lead angle) 95° (-5°)	93° (-3°)	95° (-5°)
			
			
	T-DCMxxDDMxx 12-19 (1/2-3/4)	T-DCMxxDDMxx 15 (1/2)	T-DCL.xxDCLxx 12-16 (1/2-5/8)
Insert size, mm (iC, inch)	C5-C10	C5-C10	C5-C8
Coromant Capto® size	C5-C10	C5-C10	C5-C8
Page	H11	H11	H12
CoroTurn® RC rigid clamp design	Entering angle (Lead angle) 95° (-5°)	93° (-3°)	95° (-5°)
			
			
	DCMNN 12-16 (1/2-5/8)	DDNML 15 (1/2)	DVMNL 16 (3/8)
Insert size, mm (iC, inch)	C5-C8	C5-C8	C8
Coromant Capto® size	C5-C8	C5-C8	C8
Page	H15	H16	H16
CoroTurn® HP lever design (T-Max P)	Entering angle (Lead angle) 95° (-5°)	50° (40°)	93° (-3°)
			
			
	PCLNR/L 12 (1/2)	PCMNN 12-19 (1/2-3/4)	PDJNR/L 15 (1/2)
Insert size, mm (iC, inch)	C6	C4-C10	C6
Coromant Capto® size	C6	C4-C10	C6
Page	H22	H22	H23
CoroTurn® HP lever design (T-Max P)	Entering angle (Lead angle) 93° (-3°)	45° (45°)	
			
			
	PDMNR/L 15 (1/2)	PSSNR/L 12 (1/2)	
Insert size, mm (iC, inch)	C6	C6	
Coromant Capto® size	C6	C6	
Page	H23	H24	

Coromant Capto® cutting units for multi-task machining

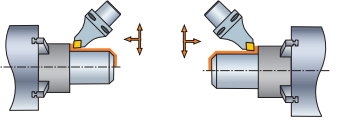
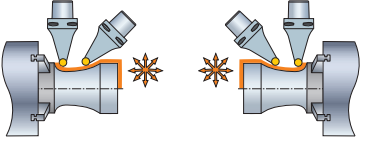
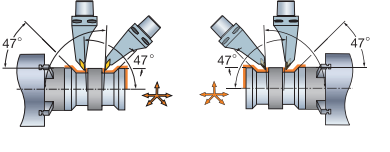
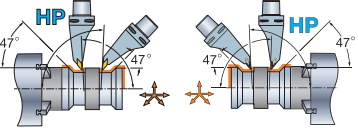
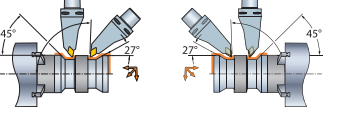
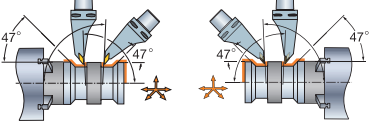
<p>CoroTurn® 107 screw clamp design</p>	<p>Entering angle (Lead angle) 95° (-5°)</p>  <p>80°</p> <p>SCMCN</p>	<p>-</p>  <p>●</p> <p>SRDCN</p>	<p>95° (-5°)</p>  <p>47°</p> <p>35°</p> <p>SVMBL</p>
<p>Insert size, mm (iC, inch)</p>	<p>12 (1/2)</p>	<p>10-16 (.394-.630)</p>	<p>16 (3/8)</p>
<p>Coromant Capto® size</p>	<p>C6</p>	<p>C6</p>	<p>C5-C6</p>
<p>Page</p>	<p>H17</p>	<p>H17</p>	<p>H18</p>
<p>CoroTurn® HP screw design (CoroTurn® 107)</p>	<p>Entering angle (Lead angle) 50° (40°)</p>  <p>47°</p> <p>35°</p> <p>SVMBR/L</p>		
<p>Insert size, mm (iC, inch)</p>	<p>16 (3/8)</p>		
<p>Coromant Capto® size</p>	<p>C6</p>		
<p>Page</p>	<p>H25</p>		
<p>CoroTurn® TR HP screw clamp design</p>	<p>Entering angle (Lead angle) 93° (-3°)</p>  <p>45°</p> <p>55°</p> <p>D13MCL</p>	<p>95° (-5°)</p>  <p>47°</p> <p>35°</p> <p>V13MBL</p>	
<p>Insert size mm</p>	<p>13</p>	<p>13</p>	
<p>Coromant Capto® size</p>	<p>C5-C6</p>	<p>C5-C6</p>	
<p>Page</p>	<p>H19</p>	<p>H20</p>	

CoroPlex™ TT

Multifunctional turning tool

Two turning tools in one dedicated for multi-task machining.

CoroPlex™ TT twin tool combines two tool holders in one:

- Reduced tool changing time.
- Saving tool pockets in the tool magazine.
- Flexible tool holders optimized in length, stability and coolant solution for multi-task machines.
- CoroTurn® RC insert clamping system with wide flexibility.
- One holder replaces two - cost reduction.



To apply the twin tool, move the Y-axis the distance h_1 , so that the insert will cut on the centre line of the workpiece. When working against a sub-spindle, the Y-axis must be offset in the opposite direction in relation to the main spindle.

Flexibility with multi-task machining

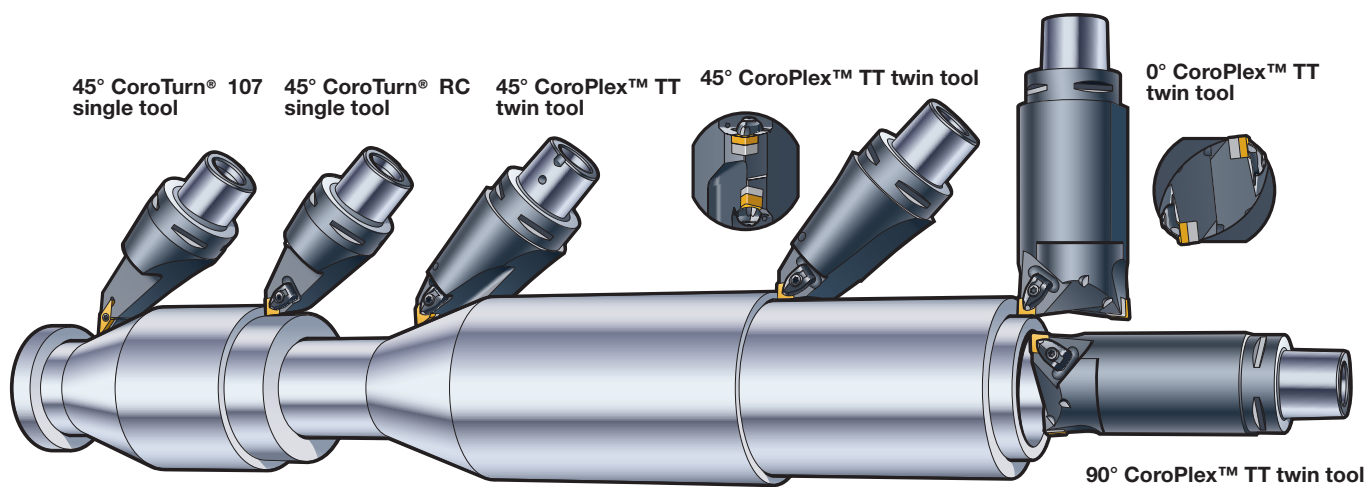

Code key for CoroPlex™ TT twin tools

C6	-	T	-	D	C	M	12	D	D	M	15	L	130
1		2		3	4	5	6	7	8	9	10	11	12

1 Coupling size mm, inch

C = Coromant Capto®
 D_{5m} = Coupling size

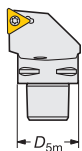

C3 D_{5m} = 32 (1.260)

C4 D_{5m} = 40 (1.575)

C5 D_{5m} = 50 (1.969)

C6 D_{5m} = 63 (2.480)

C8 D_{5m} = 80 (3.150)

Coromant Capto®

2

Type of tool
 T = Twin tool

3 and 7

Clamping system

D

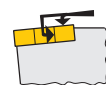

Top and hole clamping (RC)

CoroTurn® RC

4 and 8

Insert shape

C



D

**5 and 9**

Holder style

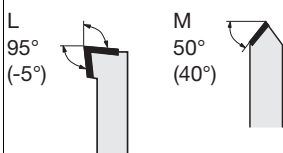

Entering angle (Lead angle)

6 and 10

Cutting edge length, l mm

**11** Hand of tool

R

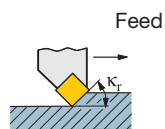

L

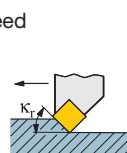

N

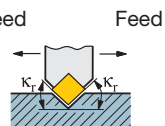
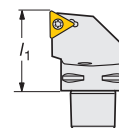
**12** Tool length, l_1 mm

Multifunctional tools CoroPlex™ TT twin tool

CoroTurn® RC rigid clamp design

Side of tool/type of insert

Entering angle:
Lead angle

DCM

κ_r 50° (95°)
-5°

Cx-T-DCMxxDDMxx

DDM

κ_r 48° (93°)
-3°



CNMM, CNGP

DNMM, DNGP, DNMX

CNMG

DNMG

CNMA, CNGA

DNMA, DNGA

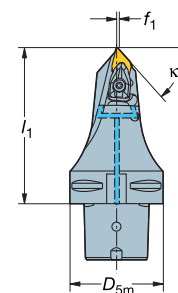
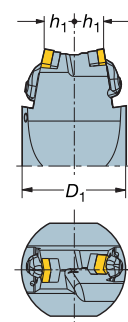
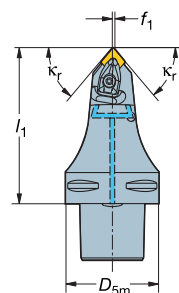

Coolant inlet: Axial through the center

Left hand style shown

Main application		iC		iC	Ordering code	Dimensions, mm, inch							Gauge inserts					
						D _{sm}	D ₁	f ₁	h ₁	l ₁	γ ¹⁾	λ _s ²⁾		ISO	ANSI	Nm ³⁾		
		1/2		1/2	C5-T-DCM12DDM15L115	50	70	0.5	20	115	-6°	-6°	1.8	CNMG 12 04 08	CNMG 432	3.9		
						1.968	2.756	.020	.787	4.528						DNMG 15 06 08	DNMG 442	
					C6-T-DCM12DDM15L105	63	70	0.5	20	105	-6°	-6°	1.8	CNMG 12 04 08	CNMG 432	3.9		
		1/2		1/2	C6-T-DCM12DDM15L130	63	70	0.5	20	130	-6°	-6°	2.5	CNMG 12 04 08	CNMG 432	3.9		
						2.480	2.756	.020	.787	5.118						DNMG 15 06 08	DNMG 442	
					C8-T-DCM16DDM15L160	80	80	0.5	24	160	-6°	-6°	4.7	CNMG 16 06 12	CNMG 543	6.4		
		5/8		1/2	C8-T-DCM16DDM15L160	80	80	0.5	24	160	-6°	-6°	4.7	CNMG 16 06 12	CNMG 543	6.4		
						3.150	3.150	.020	.945	6.299						DNMG 15 06 08	DNMG 442	3.9
		3/4		1/2	C10-T-DCM19DDM15L180	100	80	0.5	24	180	-6°	-6°	6.2	CNMG 19 06 12	CNMG 643	6.4		
						3.937	3.150	.020	.945	7.087						DNMG 15 06 08	DNMG 442	3.9

1) γ = Rake angle (valid with flat insert).

2) λ_s = Angle of inclination.

3) Insert tightening torque Nm.

L = Left hand



To apply the twin tool, move the Y-axis the distance h_1 , so that the insert will cut on the centre line of the workpiece.

For information about alternative use, see page H9

Main spare parts

Insert size									
		iC	iC	Shim	Shim screw	Key (Torx Plus)	Complete clamp set ⁴⁾	Key (Torx Plus)	
12	15	1/2	1/2	5322 234-01	5513 020-02	5680 049-01 (15IP)	5412 028-021	5680 049-01 (15IP)	
				5322 266-02	5513 020-02	5680 049-01 (15IP)	5412 028-021	5680 049-01 (15IP)	
16		5/8		5322 234-03	5513 020-07	5680 043-14 (20IP)	5412 028-031	5680 043-14 (20IP)	
				5322 236-01	5322 020-07	5680 043-14 (20IP)	5412 028-041	5680 043-14 (20IP)	

4) To modify CoroTurn® RC holders for other inserts, see clamp sets on page A445.



A9



H13



G6



A2

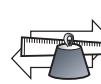

J2

A
B
C
G
H
I
J

TURN - ENG

MULTI-TASK MACHINING

Coromant Capto® cutting units

Multifunctional tools CoroPlex™ TT twin tool

CoroTurn® RC rigid clamp design

Side of tool/type of insert

Cx-T-DCL.xxDCLEX

Entering angle:
Lead angle:

DCL...
 $\kappa_r 95^\circ$
 -5°

DCL...
 $\kappa_r 95^\circ$
 -5°

CNMM, CNGP
 CNMG
 CNMA, CNGA

Coolant inlet: Axial through the center

Left hand style shown

Main application	□ iC	Ordering code	Dimensions, mm, inch										Gauge inserts		Nm ³⁾	
			D_{5m}	D_{m1} min	D_1	f_1	h_1	l_1	l_3	$\gamma^1)$	$\lambda_s^2)$	σ_{10}	ISO	ANSI		
	12	1/2	C5-T-DCL12DCL12L130	50	110	69	26.0	20	130	50	-6°	-6°	2.7	CNMG 12 04 08	CNMG 432	3.9
				1.968	4.331	2.716	1.024	.787	5.118	1.968						
	16	5/8	C6-T-DCL12DCL12L165	63	110	75	33.0	20	165	50	-6°	-6°	4.7	CNMG 12 04 08	CNMG 432	3.9
				2.480	4.331	2.953	1.299	.787	6.496	1.968						
16	5/8	C8-T-DCL16DCL16L200	80	115	80	33.0	20	200	50	-6°	-6°	7.0	CNMG 16 06 12	CNMG 543	6.4	
			3.150	4.528	3.150	1.299	.787	7.874	1.968							

1) γ = Rake angle (valid with flat insert).
 2) λ_s = Angle of inclination.
 3) Insert tightening torque Nm.

L = Left hand

Main spare parts

Insert size		Complete clamp set				
□ iC		Shim	Shim screw	Key (Torx Plus)	Complete clamp set	Key (Torx Plus)
12	1/2	5322 234-01	5513 020-02	5680 049-01 (15IP)	5412 028-021 ⁴⁾	5680 049-01 (15IP)
16	5/8	5322 234-03	5513 020-07	5680 043-14 (20IP)	5412 028-031 ⁴⁾	5680 043-14 (20IP)



⁴⁾ To modify CoroTurn® RC holders for other inserts, see clamp sets on page A445.

H 12

Spare parts

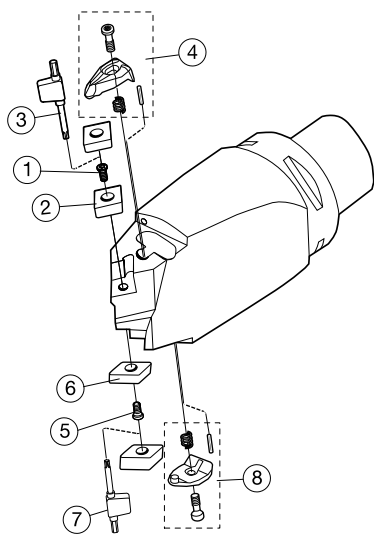
CoroPlex™ TT with CoroTurn RC rigid clamp design



	1	2		3	4	4 ¹⁾²⁾	4 ¹⁾²⁾
							
Twin tool	Shim screw	Shim	For insert thickness mm (inch).	Key (Torx Plus)	Complete clamp set	Clamp sets for ceramic inserts without hole	Clamp sets for ceramic inserts with hole
C5-T-DCL12DCL12L130	5513 020-02	5322 234-01	4.76 (.187)	5680 049-01 (15IP)	5412 028-021	5412 034-021	5412 032-021
C6-T-DCL12DCL12L165		5322 234-02 ²⁾	7.94 (.313)				
C8-T-DCL16DCL16L200	5513 020-07	5322 234-03	6.35 (.250)	5680 043-14 (20IP)	5412 028-031	5412 034-031	5412 032-031
		5322 234-04 ²⁾	7.94 (.313)				
C5-T-DCM12DDM15L115	5513 020-02	5322 234-01	4.76 (.187)	5680 049-01 (15IP)	5412 028-021	5412 034-021	5412 032-021
C6-T-DCM12DDM15L105		5322 234-02 ²⁾	7.94 (.313)				
C6-T-DCM12DDM15L130							
C8-T-DCM16DDM15L150	5513 020-07	5322 234-03	6.35 (.250)	5680 043-14 (20IP)	5412 028-031	5412 034-031	5412 032-031
		5322 234-04 ²⁾	7.94 (.313)				
C10-T-DCM19DDM15L180	5513 020-07	5322 236-01	6.35 (.250)	5680 043-14 (20IP)	5412 028-041	5412 034-041	5412 032-041
	5	6		7	8	8 ¹⁾²⁾	8 ¹⁾²⁾
							
Twin tool	Shim screw	Shim	For insert thickness mm (inch).	Key (Torx Plus)	Complete clamp set	Clamp sets for ceramic inserts without hole	Clamp sets for ceramic inserts with hole
C5-T-DCL12DCL12L130	5513 020-02	5322 234-01	4.76 (.187)	5680 049-01 (15IP)	5412 028-021	5412 034-021	5412 032-021
C6-T-DCL12DCL12L165		5322 234-02 ²⁾	7.94 (.313)				
C8-T-DCL16DCL16L200	5513 020-07	5322 234-03	4.76 (.187)	5680 043-14 (20IP)	5412 028-031	5412 034-031	5412 032-031
		5322 234-04 ²⁾	7.94 (.313)				
C5-T-DCM12DDM15L115	5513 020-02	5322 266-02	6.35 (.250)	5680 049-01 (15IP)	5412 028-021	5412 034-021	5412 032-021
C6-T-DCM12DDM15L105		5322 266-01 ²⁾	4.76 (.187)				
C6-T-DCM12DDM15L130							
C8-T-DCM16DDM15L150	5513 020-02	5322 266-02	6.35 (.250)	5680 049-01 (15IP)	5412 028-021	5412 034-021	5412 032-021
		5322 266-01 ²⁾	4.76 (.187)				
C10-T-DCM19DDM15L180	5513 020-02	5322 266-02	6.35 (.250)	5680 049-01 (15IP)	5412 028-021	5412 034-021	5412 032-021
		5322 266-01 ²⁾	4.76 (.187)				

1) For clamp set parts, see page A445.

2) Optional part delivered to separate order.

A

MULTI-TASK MACHINING

Coromant Capto® cutting units

TURN - ENG

CoroPlex™ SL mini-turret for cutting heads and blades with serrated coupling

Axial mounting of heads and blades

B

C

Coupling size		Dimensions, millimeter, inch (mm, in.)							
dm_t mm	Ordering code	D_{21} mm	D_{21} in.	dm_m mm	dm_m in.	l_1 mm	l_1 in.		
25	570-4-25-40-000-AX	50	1.968	40	1.575	12	0.472	0.3	
32	570-4-32-40-000-AX	58	2.284	40	1.575	15	0.591	0.6	

5° radial mounting of heads and blades

G

H

Coupling size		Dimensions, millimeter, inch (mm, in.)											
dm_t mm	Ordering code	b_{21} mm	b_{21} in.	b_{22} mm	b_{22} in.	dm_m mm	dm_m in.	l_{21} mm	l_{21} in.	l_{22} mm	l_{22} in.		
25	570-4-25-40-050-RA	46	1.811	48.5	1.909	40	1.575	28	1.102	15	0.591	0.4	
32	570-4-32-40-050-RA	46	1.811	49.2	1.939	40	1.575	34.5	1.358	18	0.709	0.5	

Spare parts

	1	2	3	4	5
	Screw	Key (mm)	O-ring	Coolant tube	Screw
570-4-25-40-000-AX	3212 010-257	174.1-864 (3.0)	-	5638 031-01	3212 010-358
570-4-32-40-000-AX	3212 010-307	3021 010-040 (4.0)	3671 010-113	5638 031-01	3212 010-358
570-4-25-40-050-RA	3212 010-257	174.1-864 (3.0)	-	5638 031-01	3212 010-358
570-4-32-40-050-RA	3212 010-307	3021 010-040 (4.0)	3671 010-113	5638 031-01	3212 010-358

J

H 14

Coromant Capto® cutting units

CoroTurn® RC rigid clamp design

Entering angle: **DCMNN**
 $\kappa_r 50^\circ (95^\circ)$

Lead angle: -5°



- CNMM, CNGP
- CNMG
- CNMA, CNGA

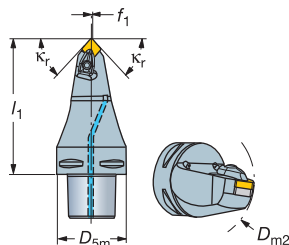

Coolant inlet: Axial through the center

Neutral style

Main application		iC	Ordering code	Dimensions, millimeter, inch (mm, in.)										Gauge inserts			
				D_{5m} mm	D_{5m} in.	D_{m2} min mm.4)	D_{m2} min in.4)	f_1 mm	f_1 in.	l_1 mm	l_1 in.	$\gamma^1)$	$\lambda_s^2)$	α_{IG}	ISO	ANSI	Nm ³⁾
	12	1/2	C5-DCMNN-00105-12	50	1.969	110	4.331	0	0	105	4.134	-6°	-6°	1.1	CNMG 12 04 08	CNMG 432	3.9
			C6-DCMNN-00090-12	63	2.480	110	4.331	0	0	90	3.543	-6°	-6°	1.4	CNMG 12 04 08	CNMG 432	3.9
	16	5/8	C6-DCMNN-00090-16	63	2.480	110	4.331	0	0	90	3.543	-6°	-6°	1.3	CNMG 16 06 12	CNMG 543	6.4
			C8-DCMNN-00150-16	80	3.150	115	4.528	0	0	150	5.906	-6°	-6°	4.0	CNMG 16 06 12	CNMG 543	6.4

1) γ = Rake angle (valid with flat insert).

2) λ_s = Angle of inclination.

3) Insert tightening torque Nm.

4) Valid in combination with clamping unit R/LC2090.

N = Neutral

Main spare parts

Insert size		Shim			Key (Torx Plus)		Complete clamp set	
	iC	Shim	Shim screw	Key (Torx Plus)		Complete clamp set	Key (Torx Plus)	
12	1/2	5322 234-01	5513 020-02	5680 049-01 (15IP)		5412 028-021 ⁵⁾	5680 049-01 (15IP)	
16	5/8	5322 234-03	5513 020-07	5680 043-14 (20IP)		5412 028-031 ⁵⁾	5680 043-14 (20IP)	

5) To modify CoroTurn® RC holders for other inserts, see clamp sets on page A445.

Coromant Capto® coupling size	Coolant nozzle
C5	5691 029-09
C6	5691 029-10
C8	5691 029-10



A9



A439



G6



A2



J2

Coromant Capto® cutting units

CoroTurn® RC rigid clamp design

DDMNL
 Entering angle: $\kappa_r 48^\circ (93^\circ)$
 Lead angle: -3°

DVMNL
 Entering angle: $\kappa_r 50^\circ (95^\circ)$
 Lead angle: -5°



DNMM, DNGP, DNMX
 DNMG
 DNMA, DNGA

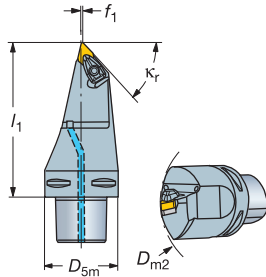

VNMG
 VNGP

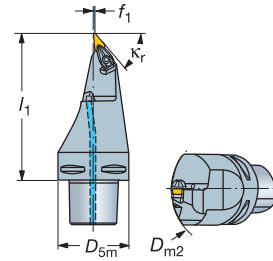

Coolant inlet: Axial through the center

Left hand style

Main application		iC	Ordering code	Dimensions, millimeter, inch (mm, in.)										Gauge inserts				
				D_{5m} mm	D_{5m} in.	D_{m2} min mm. ⁴⁾	D_{m2} min in. ⁴⁾	f_1 mm	f_1 in.	l_1 mm	l_1 in.	$\gamma^1)$	$\lambda_s^2)$	ρ_{kg}	ISO	ANSI	Nm ³⁾	
		15	1/2	C5-DDMNL-00115-15	50	1.968	110	4.331	0	0	115	4.528	-5°	-6°	1.2	DNMG 15 06 08	DNMG 442	3.9
				C6-DDMNL-00130-15	63	2.480	110	4.331	0	0	130	5.118	-5°	-6°	2.0	DNMG 15 06 08	DNMG 442	3.9
				C6-DDMNL-00130-1504	63	2.480	110	4.331	0	0	130	5.118	-5°	-6°	2.0	DNMG 15 04 08	DNMG 432	3.9
				C6-DDMNL-33120-15	63	2.480	130	5.118	33	1.299	120	4.724	-5°	-6°	2.1	DNMG 15 06 08	DNMG 442	3.9
				C6-DDMNL-33120-1504	63	2.480	130	5.118	33	1.299	120	4.724	-5°	-6°	2.1	DNMG 15 04 08	DNMG 432	3.9
				C8-DDMNL-00160-15	80	3.150	120	4.724	0	0	160	6.299	-5°	-6°	4.1	DNMG 15 06 08	DNMG 442	3.9
				C8-DDMNL-00160-1504	80	3.150	120	4.724	0	0	160	6.299	-5°	-6°	4.1	DNMG 15 04 08	DNMG 432	3.9

Main application		iC	Ordering code	Dimensions, millimeter, inch (mm, in.)										Gauge inserts				
				D_{5m} mm	D_{5m} in.	D_{m2} min mm. ⁴⁾	D_{m2} min in. ⁴⁾	f_1 mm	f_1 in.	l_1 mm	l_1 in.	$\gamma^1)$	$\lambda_s^2)$	ρ_{kg}	ISO	ANSI	Nm ³⁾	
		16	3/8	C8-DVMNL-00160-16	80	3.150	110	4.331	0	0	160	6.299	-4°	-14°	4.0	VNMG 16 04 08	VNMG 332	3.0

1) γ = Rake angle (valid with flat insert).

2) λ_s = Angle of inclination.

3) Insert tightening torque Nm.

4) Valid in combination with clamping unit R/LC2090.

L = Left hand

Main spare parts

Insert size				Coromant Capto® size			Shim screw		Shim		Key (Torx Plus)		Complete clamp set		Key (Torx Plus)	
		iC	iC	Shim screw		Shim		Key (Torx Plus)		Complete clamp set		Key (Torx Plus)				
		1506	1/2	C5-C8		5513 020-02		5322 266-02		5680 049-01 (15IP)		5412 028-021 ⁵⁾		5680 049-01 (15IP)		
		1504	1/2	C6, C8		5513 020-02		5322 266-01		5680 049-01 (15IP)		5412 028-021 ⁵⁾				
		16	3/8	C8		5513 020-09		5322 269-01		5680 049-01 (15IP)		5412 028-061		5680 049-01 (15IP)		

5) To modify CoroTurn® RC holders for other inserts, see clamp sets on page A445.

Coromant Capto® coupling size

Coromant Capto® coupling size	Coolant nozzle
C5	5691 029-09
C6	5691 029-10
C8	5691 029-10



Coromant Capto® cutting units

CoroTurn® 107 screw clamp design

Entering angle: $\kappa_r 50^\circ (95^\circ)$

Lead angle: 40°

SCMCN

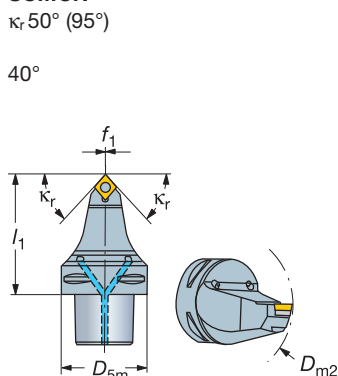

SRDCN

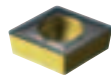
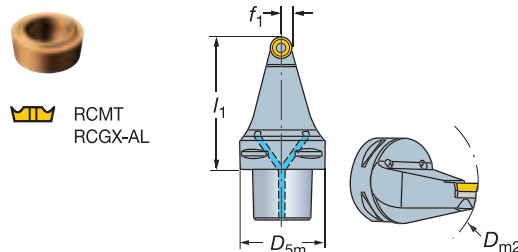

CCMT, CCGT
CCGX, CCET
CCMW



RCMT
RCGX-AL

Coolant inlet: Radial through the taper

Neutral style

Main application		iC	Ordering code	Dimensions, millimeter, inch (mm, in.)										Gauge inserts		Nm ³⁾	
				D _{5m} mm	D _{5m} in.	D _{m2} min mm. ⁴⁾	D _{m2} min in. ⁴⁾	f ₁ mm	f ₁ in.	l ₁ mm	l ₁ in.	γ ¹⁾	λ _s ²⁾		ISO		ANSI
	12	1/2	C6-SCMCN-00090-12	63	2.480	100	3.937	0	0	90	3.543	0°	0°	1.4	CCMT 12 04 08	CCMT 432	3.0

Main application		iC	Ordering code	Dimensions, millimeter, inch (mm, in.)										Gauge inserts		Nm ³⁾	
				D _{5m} mm	D _{5m} in.	D _{m2} min mm. ⁴⁾	D _{m2} min in. ⁴⁾	f ₁ mm	f ₁ in.	l ₁ mm	l ₁ in.	γ ¹⁾	λ _s ²⁾		ISO		ANSI
	10	.39	C6-SRDCN-00100-10	63	2.480	110	4.331	5	.197	100	3.937	0°	0°	1.4	RCMT 10 T3 M0	RCMT 10 T3 M0	3.0
	16	.63	C6-SRDCN-00100-16	63	2.480	110	4.331	8	.315	100	3.937	0°	0°	1.4	RCMT 16 06 M0	RCMT 16 06 M0	6.4

1) γ = Rake angle (valid with flat insert).

2) λ_s = Angle of inclination.

3) Insert tightening torque Nm.

4) Valid in combination with clamping unit R/LC2090.

N = Neutral

Main spare parts

Insert size		iC		Insert screw		Key (Torx Plus)		Shim		Shim screw		Key (Torx Plus)		Coolant tube	
		12	10	1/2	.394	5513 020-18	5680 049-01 (15IP)	5322 232-02	5512 090-03	5680 049-01 (15IP)	5691 045-01				
			16		.630	5513 020-26	5680 043-14 (20IP)	5322 110-03	5512 090-06	5680 043-14 (20IP)	5691 045-01				



A9



A464



G6



A2



J2

A
B
C
G
H
I
J

TURN - ENG

MULTI-TASK MACHINING

Coromant Capto® cutting units

Coromant Capto® cutting units

CoroTurn® 107 screw clamp design

Entering angle:
Lead angle:

SVMBL

κ_r 50° (95°)
40°



 VBMT, VBGT
VCGX, VCEX,
VCGT, VCET
 VBMTW, VCMW

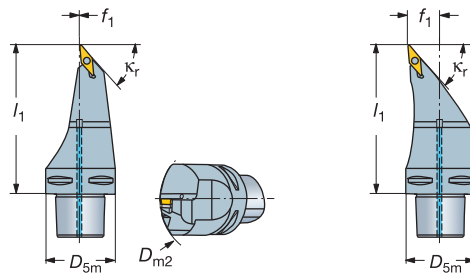

Coolant inlet: Radial through the taper

C6-SVMBL-33120-16

Left hand style

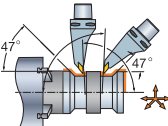
Main application		iC	Ordering code	Dimensions, millimeter, inch (mm, in.)										Gauge inserts			
				D_{5m} mm	D_{5m} in.	D_{m2} min mm.4)	D_{m2} min in.4)	f_1 mm	f_1 in.	l_1 mm	l_1 in.	γ ¹⁾	λ_s ²⁾	$\frac{R}{\mu m}$	ISO	ANSI	Nm ³⁾
	16	3/8	C5-SVMBL-00115-16	50	1.968	110	4.331	0	0	115	4.528	0°	0°	1.0	VBMT 16 04 08	VBMT 332	3.0
			C6-SVMBL-00130-16	63	2.480	110	4.331	0	0	130	5.118	0°	0°	1.8	VBMT 16 04 08	VBMT 332	3.0
			C6-SVMBL-33120-16	63	2.480	110	4.331	33	1.299	120	4.724	0°	0°	1.9	VBMT 16 04 08	VBMT 332	3.0

1) γ = Rake angle (valid with flat insert).

2) λ_s = Angle of inclination.

3) Insert tightening torque Nm.

4) Valid in combination with clamping unit R/LC2090.

L = Left hand

Main spare parts

Insert size	Insert screw	Key (Torx Plus)	Shim	Shim screw	Key (Torx Plus)
 16 3/8	5513 020-01	5680 049-01 (15IP)	5322 270-01	5512 090-01	5680 049-01 (15IP)



H 18



Coromant Capto® cutting units

CoroTurn® TR screw clamp design

Entering angle:
Lead angle:

TR-Cx-D13MCL

κ_r 48° (93°)
40°



TR-DC

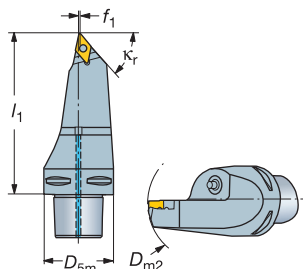
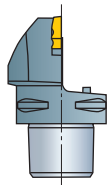

Coolant inlet: Axial through the center

Left hand style shown

Main application	Ordering code	Dimensions, millimeter, inch (mm, in.)										Gauge inserts			
		D_{5m} mm	D_{5m} in.	D_{m2} min mm.4)	D_{m2} min in.4)	f_1 mm	f_1 in.	l_1 mm	l_1 in.	$\gamma^1)$	$\lambda_s^2)$	$\lambda_s^3)$	ISO	ANSI	Nm ³⁾
	13 TR-C5-D13MCL-00115	50	1.968	150	5.906	0	0	115	4.528	0°	0°	0.8	TR-DC1308	TR-DC1308	3.0
	TR-C6-D13MCL-00130	63	2.480	150	5.906	0	0	130	5.118	0°	0°	1.6	TR-DC1308	TR-DC1308	3.0

1) γ = Rake angle (valid with flat insert).

2) λ_s = Angle of inclination.

3) Insert tightening torque Nm.

4) Valid in combination with clamping unit R/LC2090.

L = Left hand

For more information about CoroTurn TR system, see chapter A page A189

Main spare parts

Insert size	Insert screw	Key (Torx Plus)	Torque wrench	Coolant nozzle
13	5513 020-01	5680 049-01 (15IP)	5680 100-06	5691 029-02



A9



A464



G6



A2



J2

A

Coromant Capto® cutting units

CoroTurn® TR screw clamp design

Entering angle:
Lead angle:

TR-Cx-V13MBL

κ_r 50°
40°



TR-VB

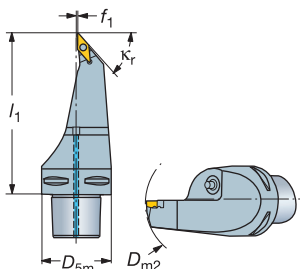
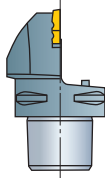

B

C

Coolant inlet: Axial through the center

Left hand style shown

Main application	Ordering code	Dimensions, millimeter, inch (mm, in.)								Gauge inserts					
		D_{5m} mm	D_{5m} in.	D_{m2} min mm. ⁴⁾	D_{m2} min in. ⁴⁾	f_1 mm	f_1 in.	l_1 mm	l_1 in.	$\gamma^{1)}$	$\lambda_s^{2)}$	ρ_{ISO}	ISO	ANSI	Nm ³⁾
	13 TR-C5-V13MBL-00115	50	1.968	150	5.906	0	0	115	4.528	0°	0°	0.8	TR-VB1308	TR-VB1308	2.0
	TR-C6-V13MBL-00130	63	2.480	150	5.906	0	0	130	5.118	0°	0°	1.6	TR-VB1308	TR-VB1308	2.0

G

1) γ = Rake angle (valid with flat insert).2) λ_s = Angle of inclination.

3) Insert tightening torque Nm.

4) Valid in combination with clamping unit R/LC2090.

L = Left hand

For more information about CoroTurn TR system, see chapter A page A189

Main spare parts

H

Insert size	Insert screw	Key (Torx Plus)	Torque wrench
13	5513 020-64	5680 049-04 (10IP)	5680 100-05

I

J



CoroTurn® HP

Coromant Capto tools for High Pressure coolant

Increased cutting speed for rough to medium machining
Chip control in finishing - secure unmanned production

When to use

Any turning machine where both high pressure coolant and Coromant Capto® coupling are available:

- Multi-task machines
- Vertical turning lathes (VTL)
- Turning centres

The characteristic reduced depth of cut and reduced feed rate in finishing operations always leads to challenges for chip control. In automated production, be it high volume mass production or machines with automatic tool changing (multi-task and vertical turning lathes), any chips gathering around the tool will result in costly machine stoppages. This new technology will provide you with total chip control giving security in unmanned production.



Fixed coolant-nozzle technology

The high pressure coolant application by way of CoroTurn HP is based on carefully developed nozzle technology based on decades of experience. Optimized nozzles give parallel laminar jets of coolant with high velocity accurately directed at the right place on the insert. The precision and character of these jets make the difference. CoroTurn HP has fixed, pre-directed, high precision nozzles mounted on the tool targeting the right place, at the right angle on the cutting edge. No setting with trials are needed, performance and security is built in with only normal tool maintenance needed.

A directional jet for maximum effect

The principle of turning with high pressure coolant is to accurately position the jet of coolant through small, sighted nozzles (dia 1 mm) to give a parallel laminar flow. This high velocity jet of coolant creates a hydraulic wedge between the top surface of the insert and the underside of the chip being removed from the component. The coolant jet has three main effects:

1. To provide localized cooling of the insert in the contact zone (A)
2. To force the chip away from the insert face quickly, reducing wear on the insert (B)
3. To help break the chip into smaller pieces and evacuate it from the cutting area

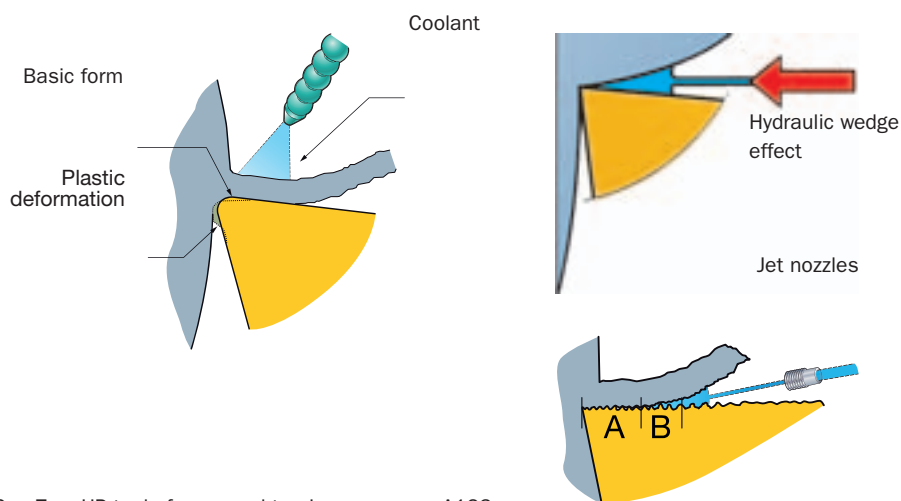

CoroTurn HP tools for general turning, see page A123.

CoroTurn HP with SL coupling, see page I12.

CoroTurn® HP cutting units

Lever design

With high pressure coolant

Entering angle: **Cx-PCLNR/L-HP**
 $\kappa_r 95^\circ$
 Lead angle: -5°

Entering angle: **Cx-PCMNN-HP**
 $\kappa_r 50^\circ (95^\circ)$
 Lead angle: -5°



- CNMM, CNGP
- CNMG
- CNMA, CNGA

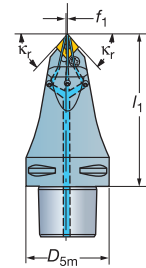
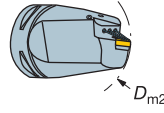
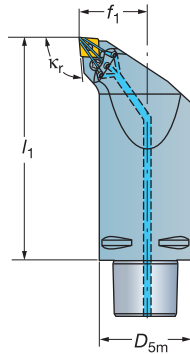
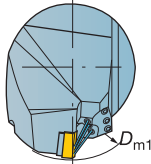

Coolant inlet: Axial through the center

Neutral

Right hand style shown

Main application	□	iC	Ordering code	Dimensions, mm, inch						Gauge inserts			
				D_{5m}	D_{m1} min ⁴⁾	f_1	l_1	$\gamma^1)$	$\lambda_s^{2)}$	T_{tight}	ISO	ANSI	Nm ³⁾
	12	1/2	C6-PCLNR/L-45165-12HP	63	110	45.0	165.0	-6°	-6°	3.5	CNMG 12 04 08	CNMG 432	5.0
				2.480	4.331	1.772	6.496						

Main application	□	iC	Ordering code	Dimensions, mm, inch						Gauge inserts				
				D_{5m}	D_{m2} min ⁴⁾	f_1	l_1	$\gamma^1)$	$\lambda_s^{2)}$	T_{tight}	ISO	ANSI	Nm ³⁾	
	12	1/2	C4-PCMNN-00095-12HP	40	185	0.0	95.0	-6°	-6°	0.7	CNMG 12 04 08	CNMG 432	5.0	
				1.575	7.284	.000	3.740							
				C5-PCMNN-00115-12HP	50	220	0.0	115.0	-6°	-6°				1.3
					1.968	8.661	.000	4.528						
				C6-PCMNN-00115-12HP	63	240	0.0	115.0	-6°	-6°				1.8
					2.480	9.449	.000	4.528						
C8-PCMNN-00150-12HP	80	315	0.0	150.0	-6°	-6°	3.8							
	3.150	12.402	.000	5.906										
19	3/4	C10-PCMNN-00110-19HP	100	315	0.0	110.0	-6°	-6°	4.9	CNMG 19 06 12	CNMG 643	5.0		
			3.937	12.402	.000	4.331								

- 1) γ = Rake angle (valid with flat insert). N = Neutral, R = Right hand, L = Left hand
 2) λ_s = Angle of inclination.
 3) Insert tightening torque Nm.
 4) Valid in combination with clamping unit R/LC2090.

Main spare parts

Insert size							
□	iC	Lever	Screw	Key (mm)	Shim	Nozzle (hole dia mm.)	Plug
12	1/2	174.3-841M	174.3-821	174.1-864 (3.0)	171.31-850M	5691 026-03 (1.0)	3214 010-253
19	3/4	174.3-842M	174.3-822M	3021 010-040 (4.0)	171.35-851M	5691 034-03 (3.5) ¹⁾	

1) When changing nozzle use key 5680 019-01 and bits 5680 021-04

For optional nozzles, see page A465



CoroTurn® HP cutting units

Lever design

With high pressure coolant

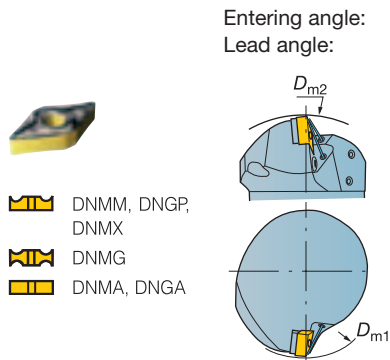

Entering angle:
Lead angle:

Cx-PDJNR/L-HP

κ_r 93°
-3°

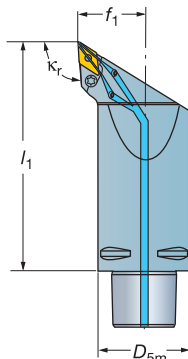

Cx-PDMNR/L-15HP

κ_r 48° (93°)
42° (-3°)

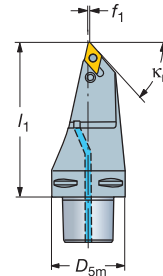

Left hand style shown

Coolant inlet: Axial through the center

Right hand style shown

Main application		iC	Ordering code	Dimensions, mm, inch							Gauge inserts			
				D_{5m}	D_{m1} min	D_{m2} min	f_1	I_1	$\gamma^{1)}$	$\lambda_s^{2)}$	$\frac{kg}{mm^3}$	ISO	ANSI	Nm ³⁾
	15	1/2	C6-PDJNR/L-45165-15HP	63	95	290.0	45.0	165.0	-6°	-7°	3.5	DNMG 15 06 08	DNMG 442	5.0
				2.480	3.740	11.417	1.772	6.496						

Main application		iC	Ordering code	Dimensions, mm, inch							Gauge inserts		
				D_{5m}	f_1	I_1	$\gamma^{1)}$	$\lambda_s^{2)}$	$\frac{kg}{mm^3}$	ISO	ANSI	Nm ³⁾	
	15	1/2	C6-PDMNR/L-00130-15HP	63	0.6	130.0	-5°	-15°	2.0	DNMG 15 06 08	DNMG 442	5.0	
				2.480	.022	5.118							

1) γ = Rake angle (valid with flat insert).

2) λ_s = Angle of inclination.

3) Insert tightening torque Nm.

R = Right hand, L = Left hand

Main spare parts

Insert size						
	iC	Lever	Screw	Key (mm)	Shim	Nozzle (hole dia mm.)
15	1/2	174.3-847M	174.3-830	174.1-864 (3.0)	171.35-851M	5691 026-03 (1.0)

For optional nozzles, see page A465



A

CoroTurn® HP cutting units

Lever design

With high pressure coolant

B

Entering angle:

Cx-PSSNR/L-HP $\kappa_r 45^\circ$

Lead angle:

45°

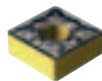

 SNMM
 SNMG
 SNMA, SNGA

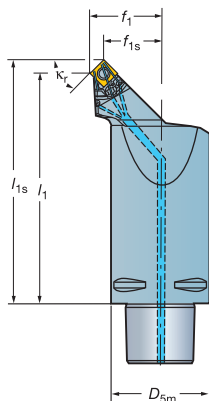
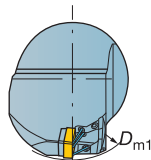

C

Coolant inlet: Axial through the center

Right hand style shown

G

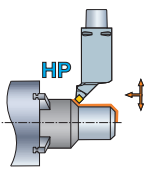
Main application	□ iC	Ordering code	Dimensions, mm, inch								Gauge inserts				
			D_{sm}	D_{m1} min ⁴⁾	f_1	f_{1s}	l_1	l_{1s}	$\gamma^1)$	$\lambda_s^{2)}$	$\frac{kg}{kg}$	ISO	ANSI	Nm ³⁾	
	12	1/2	C6-PSSNR/L-45156-12HP	63	110	45.0	36.7	156	164.3	-8°	0°	3.38	SNMG 12 04 08	SNMG 432	5.0
				2.480	4.331	1.772	1.445	6.142	6.468						

1) γ = Rake angle (valid with flat insert).2) λ_s = Angle of inclination.

3) Insert tightening torque Nm.

4) Valid in combination with clamping unit R/LC2090.

R = Right hand, L = Left hand

H

Main spare parts

Insert size		Lever		Screw	Key (mm)	Shim	Nozzle (hole dia mm.)
□ 12	iC 1/2	174.3-841M	174.3-821	174.1-864 (3.0)	174.3-851M	5691 026-03 (1.0)	

For optional nozzles, see page A465

I

J



CoroTurn® HP cutting units

Screw clamp design

With high pressure coolant

Entering angle: **Cx-SVMBR/L-HP**
 κ_r 50°
 Lead angle: 40°



 VBMT, VBGT
 VCGX, VCEX,
 VCGT, VCET
 VBW, VCMW

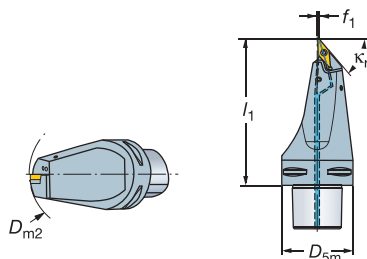

Coolant inlet: Axial through the center

Right hand style shown

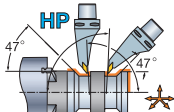
Main application	iC	Ordering code	Dimensions, mm, inch							Gauge inserts			
			D_{5m}	D_{m2} min ⁴⁾	f_1	l_1	$\gamma^1)$	$\lambda_s^2)$	$\alpha_{AG}^3)$	ISO	ANSI	Nm ³⁾	
	16	3/8	C6-SVMBR/L-00130-16HP	63	145	0	130	0°	0°	1.84	VBMT 16 04 08	VBMT 332	3
				2.480	5.709	.000	5.118						

1) γ = Rake angle (valid with flat insert).

2) λ_s = Angle of inclination.

3) Insert tightening torque Nm.

4) Valid in combination with clamping unit R/LC2090.

R = Right hand, L = Left hand

Main spare parts

Insert size		Insert screw (thread)	Key (Torx Plus)	Shim	Shim screw	Key (mm)	Nozzle (hole dia mm.)
16	3/8	5513 020-01 (M3.5)	5680 049-01 (15IP)	5322 270-01	5512 090-01	5680 049-01 (3.5)	5691 026-03 (1.0)

For optional nozzles, see page A467



A

MULTI-TASK MACHINING

CoroTurn® SL

TURN - ENG

CoroTurn® SL

Coromant Capto® adaptor

B

Coromant Capto® 45°**Cx-570-..RX-045-L1**

Coolant inlet: Axial through the center

C

Right hand style shown

Coupling size		Dimensions, millimeter, inch (mm, in.)										
dm_t mm	Ordering code	Shank style		D_1 mm	D_1 in.	D_{5m} mm	D_{5m} in.	f_1 mm	f_1 in.	l_1 mm	l_1 in.	$\frac{R}{L}$
32	C5-570-32-RX-045-L1	45°		40	1.575	50	1.968	2	0.079	90	3.543	1.1
32	C6-570-32-RX-045-L1			45	1.772	63	2.480	2	0.079	100	3.937	1.7
40	C6-570-40-RX-045-L1			45	1.772	63	2.480	2	0.079	100	3.937	1.8
40	C8-570-40-RX-045-L1			50	1.969	80	3.150	5	0.197	135	5.315	3.7

R = Right hand, L = Left hand

Main spare parts

G

Coromant Capto®	Screw	Key (mm)	Plug
Cx-570-32-RX-045-L1	3212 010-308	3021 010-040 (4.0)	5643 045-01
Cx-570-40-RX-045-L1	3212 010-358	3021 010-050 (5.0)	5643 045-01

For complete assortment see page I70.

H

I

J

H 26

SANDVIK
Coromant

CoroTurn® SL70

Coromant Capto® adaptor

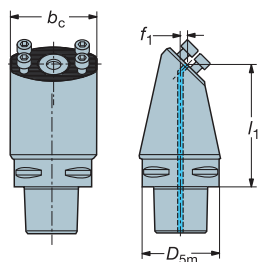

Coromant Capto® 45°



Coolant inlet: Axial through the center

With internal coolant supply

Right hand style shown

Type	Ordering code	Shank style	Coupling size, mm	Dimensions, mm, inch			
				D_{5m}	f_1	l_1	
	C6-SL70-RX-045-100	45°	70	63	5	100	2.7
				2.480	.197	3.937	2.7

For complete assortment see page I106.

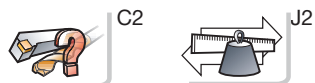

A
B
C
G
H
I
J

TURN - ENG

MULTI-TASK MACHINING

Coromant Capto® adaptors

Adaptors for shank tools

Radial mounting

ASHA

C6-ASHA-50071-32M

Coolant inlet: Axial through the center

Neutral style shown

Metric version

Coupling size	Ordering code	Dimensions, mm								
		D_1	D_{5m}	b_{21}	b_{22}	h_{21}	h_{23}	l_1	l_{21}	$\frac{kg}{kg}$
C3	C3-ASHA-25040-12	60	32	25	20	25	12	28	40	0.4
C4	C4-ASHA-25046-16	70	40	25	20	32	16	30	46	0.6
C5	C5-ASHA-38058-20M	90	50	38	23	45	20	38	58	1.4
C6	C6-ASHA-38060-20M	90	63	38	23	45	20	40	60	1.7
	C6-ASHA-45071-25M	110	63	45	30	55	25	45	71	2.6
C8	C6-ASHA-50071-32M	130	63	50	40	65	32	45	71	3.2
	C8-ASHA-45085-25	110	80	45	30	55	25	60	85	4.0
C10	C8-ASHA-55085-32M	142	80	55	40	65	32	53	85	4.6
	C10-ASHA-55090-32	145	100	55	40	65	32	58	90	5.7

Radial mounting

ASHA-AM

ASHA-U

Coolant inlet: Axial through the center

Neutral style shown

Inch version

Coupling size	Ordering code	Dimensions, inch								
		D_1	D_{5m}	b_{21}	b_{22}	h_{21}	h_{23}	l_1	l_{21}	$\frac{lbs}{kg}$
C4	C4-ASHA-25046-10U		1.575	.984			.625	1.180	1.810	2.20
C5	C5-ASHA-30055-12U		1.968	1.181	.581		.750	1.380	2.150	2.93
	C5-ASHA-38057-12-AM	3.543	1.968	1.496	.906	1.772	.750	1.457	2.244	3.02
C6	C6-ASHA-38059-12-AM	3.543	2.480	1.496	.906	1.772	.750	1.575	2.323	3.75
	C6-ASHA-38066-12U	5.118	2.480	1.496	.591		.750	1.580	2.340	5.11
	C6-ASHA-45071-16-A	4.331	2.480	1.772	1.181	2.165	1.000	1.795	2.795	5.65
C8	C8-ASHA-55085-20-AM	5.591	3.150	2.165	1.575	2.559	1.250	2.087	3.337	10.14

Warning!

The adaptors are designed for automatic tool change.

Make sure that there is no risk of interference in magazine and tool changing cycle.

H 28

Adaptors for shank tools

Axial mounting

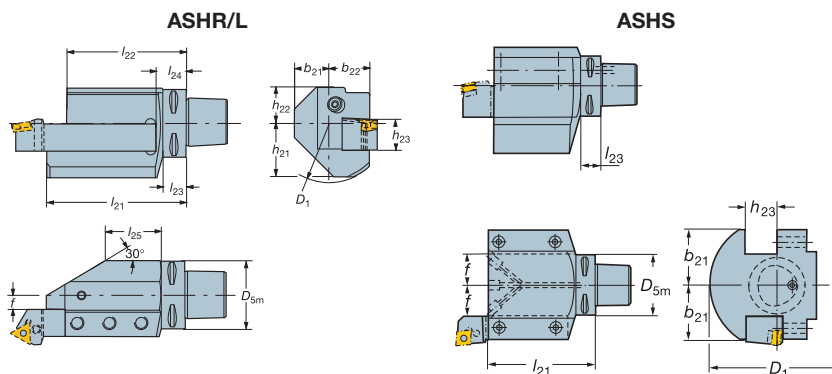
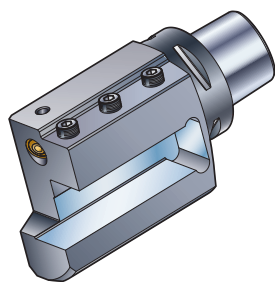

Coolant inlet: Axial through the center

Metric version

Right hand style

Neutral style

Coupling size	Ordering code	Dimensions, mm													
		D_1	D_{5m}	b_{21}	b_{22}	f	h_{21}	h_{22}	h_{23}	l_{21}	l_{22}	l_{23}	l_{24}	$\frac{R}{L}$	
C3	C3-ASHR/L-18085-12	48	32	16.5	18	6			12		85	80	15	18	0.5
C4	C4-ASHR/L-23104-16	65	40	20.5	23	7			16		104	99	20	24	1.0
C5	C5-ASHR/L-30098-20	90	50	29	30	10	41	33	20		98	88	20	23	2.5
C6	C6-ASHR/L-30100-20	90	63	29	30	10	41	33	20		100	90	22	25	2.5
	C6-ASHR/L-38130-25	110	63	32	38	13	50	33	25		130	112	22	28	3.4
C8	C8-ASHR/L-40140-32	110	80	40	40	8	55	30	32		140	130	30	35	5.1
C10	C10-ASHR/L-50150-32	145	100	50	50	18	65	30			150	136	37	41	8.7
C6	C6-ASHS-58115-32	140	63	58		33			32		115		22		7.3
C8	C8-ASHS-73160-32	165	80		73	41			32		160		30	30	13.1

R = Right hand, L = Left hand

Axial mounting

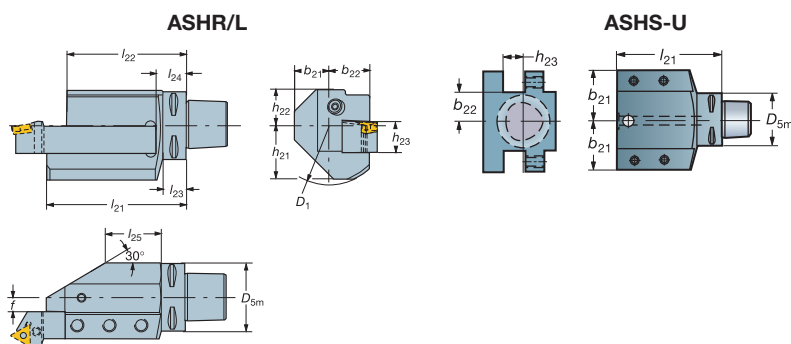
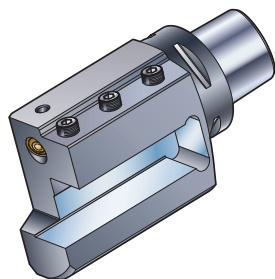

Coolant inlet: Axial through the center

Inch version

Right hand style

Neutral style

Coupling size	Ordering code	Dimensions, inch													
		D_1	D_{5m}	b_{21}	b_{22}	f	h_{21}	h_{22}	h_{23}	l_{21}	l_{22}	l_{23}	l_{24}	$\frac{R}{L}$	
C5	C5-ASHR/L-30098-12-A	3.543	1.968	1.142	1.181	.431	1.614	1.29	.750		3.858	3.465	.787	.906	4.67
C6	C6-ASHR/L-30100-12-A	3.543	2.480	1.142	1.181	.431	1.614	1.29	.750		3.937	3.543	.866	.984	5.29
	C6-ASHR/L-38130-16-A	4.331	2.480	1.260	1.496	.496	1.968	1.29	1.000		5.118	4.409	.866	1.102	7.50
C8	C8-ASHR/L-40140-20-A	4.331	3.150	1.575	1.575	.325	2.165	1.18	1.250		5.512	5.118	1.18	1.378	11.84
C5	C5-ASHS-47088-12U		1.968	1.831	1.060				.750		3.465				6.83
C6	C6-ASHS-54090-12U		2.480	2.106	1.340				.750		3.543				2.20

R = Right hand, L = Left hand



Adaptors for shank tools

Angular mounting

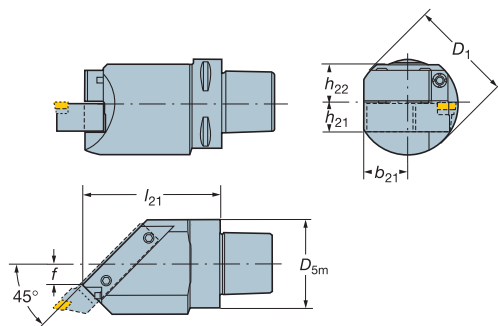
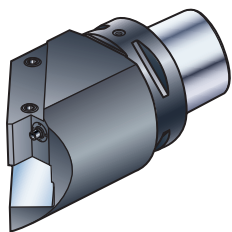

Normal use is a left hand cutting tool in a right hand adaptor

Coolant inlet: Axial through the center

Metric version

Right hand style shown

Coupling size	Ordering code	Dimensions, mm							
		D_1	D_{5m}	b_{21}	f	h_{21}	h_{22}	l_{21}	$\frac{L_{21}}{L_{22}}$
C5	C5-ASHR/L45-36097-20	72	50	30.6	15	20	26	97	1.7
C6	C6-ASHR/L45-36099-20	72	63	31.5	15	20	28	99	2.2
C8	C8-ASHR/L45-50135-32	140	80	45	17	32	40	135	6.5

Inch version

Coupling size	Ordering code	Dimensions, inch							
		D_1	D_{5m}	b_{21}	f	h_{21}	h_{22}	l_{21}	$\frac{L_{21}}{L_{22}}$
C5	C5-ASHR/L45-36097-12-A	2.835	1.968	1.205	.618	.750	1.024	3.791	3.75
C6	C6-ASHR/L45-36099-12-A	2.835	2.480	1.224	.618	.750	1.102	3.870	4.83
C8	C8-ASHR/L45-50135-20-A	5.512	3.150	1.772	.677	1.250	1.575	5.307	14.99

R = Right hand, L = Left hand

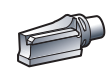

Adaptor for CoroCut® and T-Max Q-Cut® parting blades See page H32



H34



G6



J2

Mini-turret for shank tools

Axial mounting

ASHR/L3

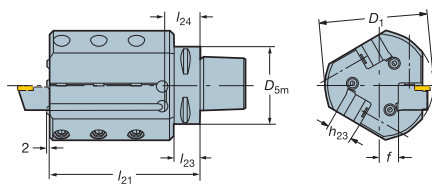
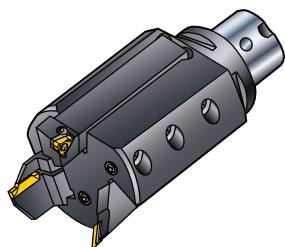

Coolant inlet: Axial through the center

Metric version

Right hand style shown

Coupling size	Ordering code	Dimensions, mm							
		D_1	D_{5m}	f	h_{23}	l_{21}	l_{23}	l_{24}	$\frac{kg}{lb}$
C5	C5-ASHR/L3-36123-20	90	50	16	20	123	20	26	3.4
C6	C6-ASHR/L3-36125-20	90	63	16	20	125	22	28	3.8
C8	C8-ASHR/L3-45150-32	120	80	20	32	150	30	36	7.5

Inch version

Coupling size	Ordering code	Dimensions, inch							
		D_1	D_{5m}	f	h_{23}	l_{21}	l_{23}	l_{24}	$\frac{lbs}{kg}$
C5	C5-ASHR/L3-36123-12-A	3.543	1.968	.614	.750	4.842	.787	1.024	7.85
C6	C6-ASHR/L3-36125-12-A	3.543	2.480	.614	.750	4.921	.866	1.102	8.16
C8	C8-ASHR/L3-46150-20-A	4.724	3.150	.811	1.250	5.906	1.181	1.417	17.01

R = Right hand, L = Left hand

Warning!

The adaptors are designed for automatic tool change.

Make sure that there is no risk of interference in magazine and tool changing cycle.



Adaptor for CoroCut® and T-Max Q-Cut® parting blades See page H32



H34



G6



J2

Adaptor for CoroCut® and T-Max Q-Cut® parting blades

Coromant Capto®

Radial mounting

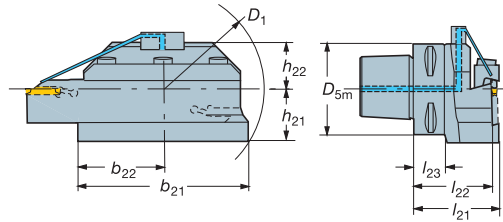
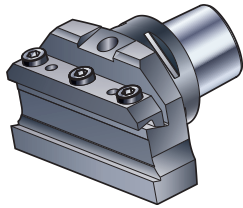

Neutral style shown

For blade size	Coupling size	Ordering code	Dimensions, mm, inch									
			D_{5m}	b_{21}	b_{22}	D_1	h_{21}	h_{22}	l_{21}	l_{22}	l_{23}	
21	C5	C5-APBA-40058-21	50	80	40	100	30	25.2	58	53	20	1.30
25	C6	C6-APBA-60060-25	1.968	3.150	1.575	3.937	1.181	.992	2.284	2.087	.787	2.30
			63	120	60	141	37	32	60	55	22	
25	C8	C8-APBA-60068-25	2.480	4.724	2.362	5.551	1.457	1.260	2.362	2.165	.866	3.30
			80	120	60	145	40.5	40	68	63	30	
45	C6	C6-APBA-80068-45	3.150	4.724	2.362	5.709	1.594	1.575	2.677	2.480	1.181	5.42
			63	160	80	198	72	42	68	60.5	23.2	
45	C8	C8-APBA-80068-45	2.480	6.299	3.150	7.795	2.835	1.654	2.677	2.382	.913	5.42
			80	160	80	198	72	42	68	60.5	31.2	
45	C10	C10-APBA-80075-45	3.150	6.299	3.150	7.795	2.835	1.654	2.677	2.382	1.228	6.60
			100	160	80	190	61.7	50.5	75	68	36	
			3.937	6.299	3.150	7.480	2.429	1.988	2.953	2.677	1.417	

Adaptor for CoroCut® and T-Max Q-Cut® parting blades

Coromant Capto®

Axial mounting

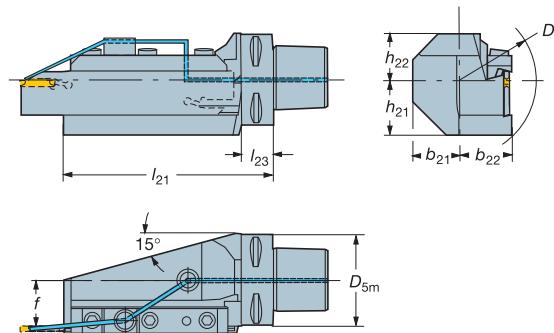
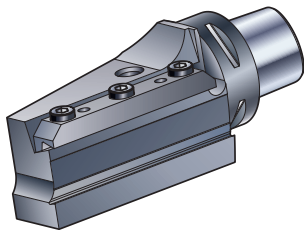

Right hand style shown

For blade size	Coupling size	Ordering code	Dimensions, mm, inch									
			D_{5m}	b_{21}	b_{22}	D_1	f	h_{21}	h_{22}	l_{21}	l_{23}	
21	C4	C4-APBR/L-26110-21	40	20.5	26	76	21	30	20.5	110	20	0.90
			1.575	.807	1.024	2.992	.827	1.181	.807	4.331	.787	1.30
			50	25.5	31	87	26	30	26	95	20	
25	C5	C5-APBR/L-31095-21	1.968	1.004	1.220	3.425	1.024	1.181	1.024	3.740	.787	1.12
			50	25.5	31	80	26	30	25.5	110	20	
			1.968	1.004	1.220	3.150	1.024	1.181	1.004	4.331	.787	
25	C6	C6-APBR/L-37147-25	63	32	37	106	32	38	32	147	22	3.22
			2.480	1.260	1.457	4.173	1.260	1.496	1.260	5.787	.866	2.00
			63	32	37	100	32	38	32	147	22	
25	C8	C8-APBR/L-46155-25	2.480	1.260	1.457	3.937	1.260	1.496	1.260	5.787	.866	6.10
			80	40	45.5	122	40.5	40.5	40.5	155	30	
			3.150	1.575	1.791	4.803	1.594	1.594	1.594	6.102	1.181	
45	C8	C8-APBR/L-46155-25X	80	40.5	45.5	115	40.5	40.5	40.5	155	30	3.16
			3.150	1.594	1.791	4.528	1.594	1.594	1.594	6.102	1.181	10.50
			100	50.5	60	160	53	61.7	50.5	205	36	
			3.937	1.988	2.362	6.299	2.087	2.429	1.988	8.071	1.417	

R = Right hand, L = Left hand

Warning!
 The adaptors are designed for automatic tool change.
 Make sure that there is no risk of interference in magazine and tool changing cycle.

Coolant adaptor ordered separately. See page B32



Adaptor for CoroCut® and T-Max Q-Cut® parting blades

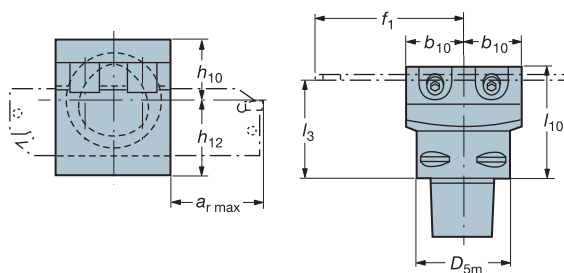

For blade size	Coupling size	Ordering code	Dimensions, mm, inch								
			$a_r \text{ max}$	b_{10}	D_{5m}	f_1	h_{10}	h_{12}	l_3		l_{10}
21	C4	C4-151.2-25040-21	44.45	24.89	40	69.34	24.89	29.97	40.13	45.21	0.68
			1.750	.980	1.575	2.730	.980	1.180	1.580	1.780	
21	C5	C5-151.2-33040-21	44.45	33.02	50	77.47	32	35.05	40.13	45.21	1.10
			1.750	1.300	1.968	3.050	1.260	1.380	1.580	1.780	
25	C5	C5-151.2-33040-25	76.2	33.02	50	109.22	32	35.05	40.13	45.21	1.13
			3.000	1.300	1.968	4.300	1.260	1.380	1.580	1.780	



H35



G6



J2

Spare parts

Radial mounting

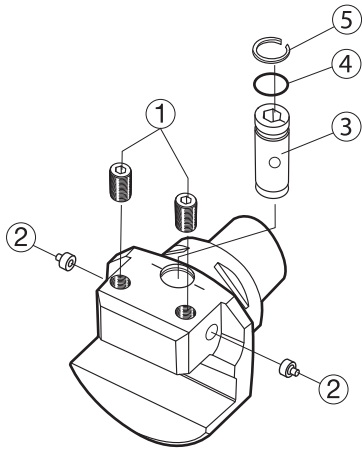

	1	2	3	4	5	
	Screw	NPT	Coolant nozzle	Valve bolt	O-ring	Circlip
C3-ASHA-25040-12	3214 020-359		5691 029-08	5692 035-05	5641 005-08	-
C4-ASHA-25046-10U	3214 010-408	1/8	-			
C4-ASHA-25046-16	3214 020-359		5691 029-08	5692 035-05	5641 005-08	-
C5-ASHA-30055-12U	3214 010-408	1/8	-			
C5-ASHA-38057-12-AM	3214 020-461		5691 029-09	5692 035-04	5641 005-79	3421 105-015
C6-ASHA-38066-12U	3214 010-459	1/8	-			
C6-ASHA-38059-12-AM	3214 020-411		5691 029-09	5692 035-04	5641 005-79	3421 105-015
C8-ASHA-45085-25	3214 020-512		5691 029-09	5692 035-04	5641 005-79	3421 105-015
C8-ASHA-55085-20-AM	3214 020-512		5691 029-09	5692 035-04	5641 005-79	3421 105-015
C5-ASHA-38058-20M	3214 020-461		5691 029-09	5692 035-04	5641 005-79	3421 105-015
C6-ASHA-38060-20M	3214 020-411		5691 029-09	5692 035-04	5641 005-79	3421 105-015
C6-ASHA-45071-16-A	3214 020-512		5691 029-09	5692 035-04	5641 005-79	3421 105-015
C6-ASHA-45071-25M	3214 040-462		5691 029-09	5692 035-04	5641 005-79	3421 105-015
C6-ASHA-50071-32M	3214 040-462		5691 029-09	5692 035-04	5641 005-79	3421 105-015
C8-ASHA-55085-32M	3214 020-512		5691 029-09	5692 035-04	5641 005-79	3421 105-015
C8X-ASHA-55090-32M	3214 020-512		5691 029-09	5692 035-04	5641 005-79	3421 105-015

Axial mounting

Cx-ASHA/ASHS

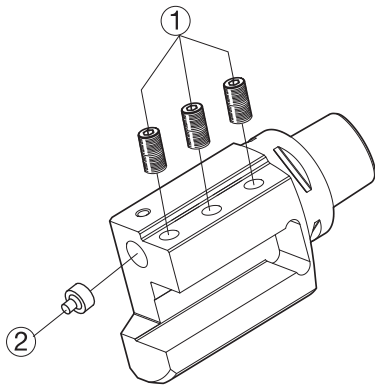

	1	2	3	4	5	
	Screw	NPT	Coolant nozzle	Valve bolt	O-ring	Circlip
C3-ASHR/L-18085-12	3214 020-358		5691 029-08	-	-	-
C4-ASHR/L-23104-16	3214 020-409		5691 029-09	-	-	-
C5-ASHS-47088-12U	3214 010-408	1/8	-			
C5-ASHR/L-30098-12-A	3214 020-461		5691 029-10			
C5-ASHR/L-30098-20	3214 020-461		5691 029-10			
C6-ASHS-54090-12U	3214 010-408	1/8	-			
C6-ASHR/L-30100-12-A	3214 020-411		5691 029-10			
C6-ASHR/L-38130-16-A	3214 020-512		5691 029-10			
C6-ASHR/L-30100-20	3214 020-461		5691 029-10			
C6-ASHR/L-38130-25	3214 020-512		5691 029-10			
C6-ASHR/L-40140-32	3214 020-512		5691 029-10			
C6-ASHS-58115-32	3214 040-462		5691 029-09			
C8-ASHS-73160-32	3214 020-512		5691 029-10	5692 035-04	5641 005-79	3421 105-015
C8-ASHR/L-40140-20-A	3214 020-512		5691 029-10			
C8X-ASHR/L-50143-32	3214 020-512		5691 029-10			
C10-ASHR/L-50150-32	3214 020-512		5691 029-10	5692 035-04	5641 005-79	3421 105-015

Cx-ASHR/L3

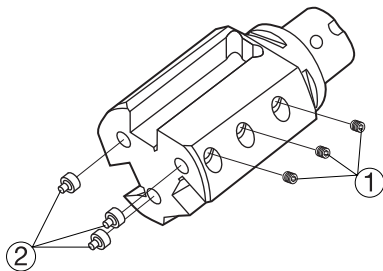

	1	2
	Screw	Coolant nozzle
C5-ASHR/L3-36123-12-A	3214 020-512	5691 029-09
C5-ASHR/L3-36123-20	3214 020-512	5691 029-09
C6-ASHR/L3-36125-12-A	3214 020-512	5691 029-09
C6-ASHR/L3-36125-20	3214 020-512	5691 029-09
C8-ASHR/L3-48150-12-A	3214 020-512	5691 029-10
C8-ASHR/L3-48150-32	3214 020-512	5691 029-10

Angular mounting

Cx-ASHR45

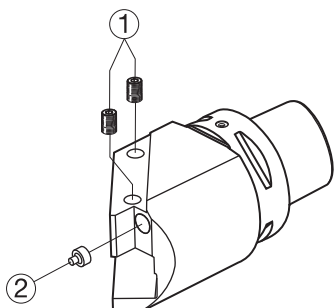

	1	2
	Screw	Coolant nozzle
C5-ASHR/L45-36097-12-A	3214 020-461	5691 029-09
C5-ASHR/L45-36097-20	3214 020-461	5691 029-09
C6-ASHR/L45-36099-12-A	3214 020-411	5691 029-09
C6-ASHR/L45-36099-20	3214 020-461	5691 029-09
C8-ASHR/L45-50135-20-A	3214 020-512	5691 029-09
C8-ASHR/L45-50135-32	3214 020-512	5691 029-09

Spare parts

Radial mounting

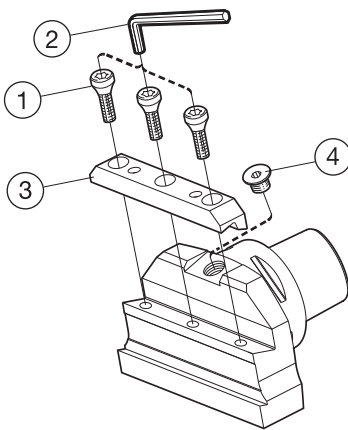

	1	2	3	4	Optional coolant adapter ²⁾
Adaptor	Screw	Key (mm)	Clamp	Plug	
C5-APBA-40058-21	3212 010-410	3021 010-060 (6.0)	5412 120-01	5519 055-01	5691 050-011
C6-APBA-60060-25	3212 010-411	3021 010-060 (6.0)	5412 120-02	5519 055-01	5691 050-011
C8-APBA-60068-25	3212 010-411	3021 010-060 (6.0)	5412 120-02	5519 055-01	5691 050-011
C6-APBA-80068-45	3212 010-412	3021 010-060 (6.0)	5412 120-03	5519 055-01	5691 050-011
C8-APBA-80068-45	3212 010-412	3021 010-060 (6.0)	5412 120-03	5519 055-01	5691 050-011

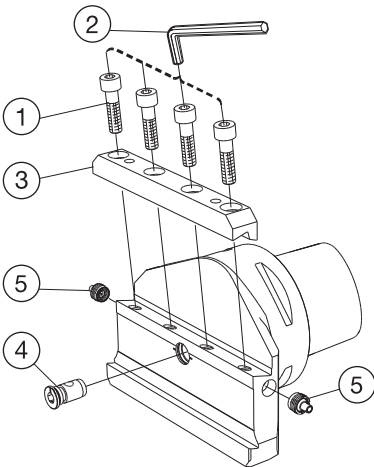

	1	2	3	4	5
	Screw	Key (mm)	Clamp	Valve bolt	Nozzle (thread)
C10-APBA-80075-45	3212 010-412	3021 010-060 (6.0)	5412 120-03	5692 035-04	5691 034-03 (M10) ¹⁾

¹⁾ When changing nozzle use key 5680 019-01 and bits 5680 021-03

²⁾ To be ordered separately

Spare parts

Axial mounting

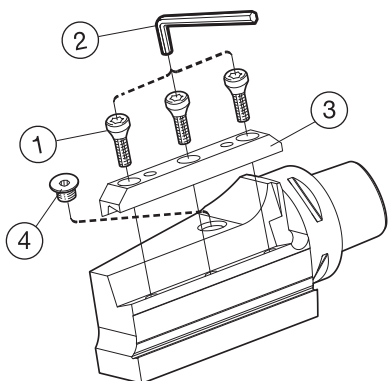

	1	2	3	4	
Adaptor	Screw	Key (mm)	Clamp	Plug	Optional coolant adapter ²⁾
C5-APBR/L-31095-21	3212 010-410	3021 010-060 (6.0)	5412 120-01	5519 055-01	5691 050-011
C6-APBR/L-37147-25	3212 010-411	3021 010-060 (6.0)	5412 120-02	5519 055-01	5691 050-011
C8-APBR/L-46155-25	3212 010-411	3021 010-060 (6.0)	5412 120-02	5519 055-01	5691 050-011

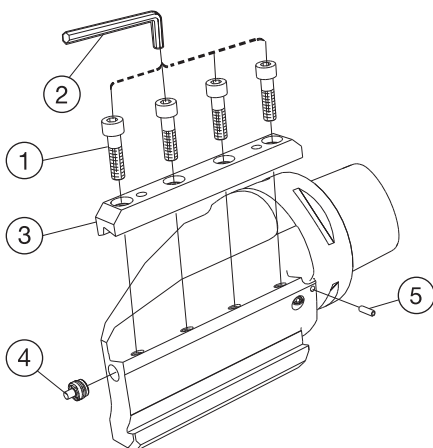

	1	2	3	4	5
Adaptor	Screw	Key (mm)	Clamp	Nozzle (thread)	Spring pin
C4-APBR/L-26110-21	3212 010-411	3021 010-060 (6.0)	5412 120-01	5691 034-01 (M8) ¹⁾	3113 030-457
C5-APBR/L-31110-21	3212 010-411	3021 010-060 (6.0)	5412 120-01	5691 034-01 (M10) ¹⁾	3113 030-457
C6-APBR/L-37147-25X	3212 010-411	3021 010-060 (6.0)	5412 120-02	5691 034-01 (M10) ¹⁾	3113 030-457
C8-APBR/L-46155-25X	3212 010-411	3021 010-060 (6.0)	5412 120-02	5691 034-01 (M10) ¹⁾	3113 030-457
C10-APBR/L-60205-45	3212 010-412	3021 010-060 (6.0)	5412 120-03	5691 034-03 (M10) ¹⁾	3113 030-457

¹⁾ When changing nozzle use key 5680 019-01 and bits 5680 021-03

²⁾ To be ordered separately

Adaptor for CoroCut® and T-Max Q-Cut® parting blades

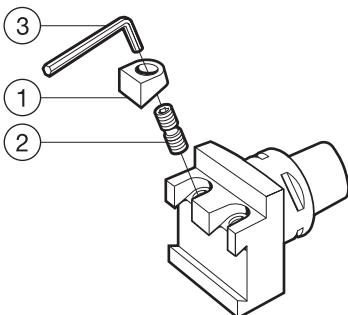

	1	2	3
Adaptor	Clamp	Clamp screw	Key (Size, mm)
C4-151.2-25040-21	150.2-820	269-833	3021 010-040 (4.0)
C5-151.2-33040-21	150.2-820	269-833	3021 010-040 (4.0)
C6-151.2-43045-21			
C5-151.2-33040-25			
C6-151.2-43045-25			

¹⁾ Accessories to be ordered separately

Boring bar adaptors for multi-task machining

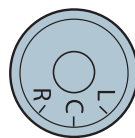
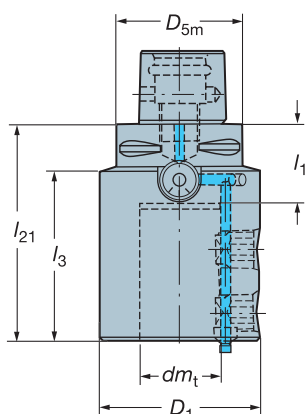
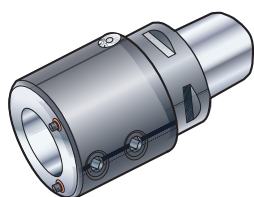

Technical information:

C = Coolant goes straight through the centre

L = Left coolant nozzle will get coolant

R = Right coolant nozzle will get coolant

l_1 = programming length

Coolant inlet: Axial through the center

Coupling size	Ordering code	Dimensions, millimeter, inch (mm, in.)													
		dm_1 mm	dm_1 in.	D_1 mm	D_1 in.	D_{5m} mm	D_{5m} in.	l_1 mm	l_1 in.	l_3 mm	l_3 in.	l_{21} mm	l_{21} in.		
C5	C5-131-00100-25	25	0.984	63	2.480	50	1.968	43	1.693	80	3.150	100	3.937	2.0	
C6	C6-131-00098-25	25	0.984	63	2.480	63	2.480	41	1.614			98	3.858	2.4	
	C6-131-00112-40	40	1.575	80	3.150	63	2.480	41	1.614	90	3.543	112	4.409	3.5	
C8	C8-131-00098-25	25	0.984	63	2.480	80	3.150	41	1.614	50	1.968	98	3.858	3.4	
	C8-131-00112-40	40	1.575	80	3.150	80	3.150	41	1.614			112	4.409	4.3	

Spare parts

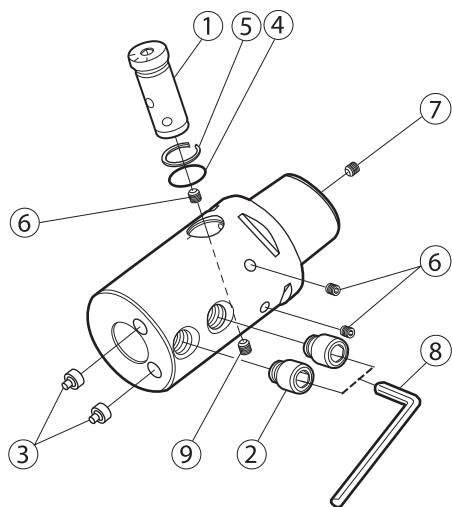

	1	2	3	4	5
	Valve bolt	Screw	Coolant nozzle	O-ring	Circlip width
C5-131-00100-25	5692 035-03	5514 012-02	5691 029-09	5641 005-06	3421 105-020
C6-131-00098-25	5692 035-01	5514 012-02	5691 029-09	5641 005-06	3421 105-020
C6-131-00112-40	5692 035-01	5514 012-01	5691 029-10	5641 005-06	3421 105-020
C8-131-00098-25	5692 035-02	5514 012-02	5691 029-09	5641 005-06	3421 105-020
C8-131-00112-40	5692 035-02	5514 012-01	5691 029-10	5641 005-06	3421 105-020
	6	7	8	9	
	Screw	Spring plunger	Key	Screw	
C5-131-00100-25	3214 010-355 (DIN913-M6x6-45H)	5514 064-01	3021 010-080 (DIN911-8)	3214 010-406	
C6-131-00098-25	3214 010-355 (DIN913-M6x6-45H)	5514 064-01	3021 010-080 (DIN911-8)	3214 010-406	
C6-131-00112-40	3214 010-355 (DIN913-M6x6-45H)	5514 064-01	3021 010-100 (DIN911-10)	3214 010-406	
C8-131-00098-25	3214 010-355 (DIN913-M6x6-45H)	5514 064-01	3021 010-080 (DIN911-8)	3214 010-406	
C8-131-00112-40	3214 010-355 (DIN913-M6x6-45H)	5514 064-01	3021 010-100 (DIN911-10)	3214 010-406	

For cylindrical sleeves, see page A320.

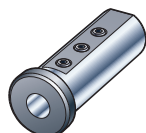

G6

A
B
C
G
H
I
J

TURN - ENG

MULTI-TASK MACHINING HSK solid holding tools

Boring bar adaptors for multi-task machining

HSK form A/C/T

Radial mounting

Metric version

Coolant inlet: Axial through the center

Neutral style shown

HSK size	Ordering code	Dimensions, mm									kg
		D_1	D_{5m}	b_{21}	b_{22}	h_{21}	h_{23}	l_1	l_{21}		
63	392.419-63-ASHA-25	110	63	45	30	55	25	65	91	2.7	
100	392.419-100-ASHA-32	142	100	55	40	65	32	68	100	5.7	

Axial mounting

Coolant inlet: Axial through the center

Metric version

Right hand style

HSK size	Ordering code	Dimensions, mm											kg
		D_1	D_{5m}	b_{21}	b_{22}	f	h_{23}	l_{21}	l_{22}	l_{23}	l_{24}		
63	392.419-63-ASHR/L-25	103.5	63	32	38	13	25	152	134	42	50	3.7	
100	392.419-100-ASHR/L-32	110	100	42.5	40	8	32	155	145	45	50	6.3	

R = Right hand, L = Left hand

Warning!

The adaptors are designed for automatic tool change.

Make sure that there is no risk of interference in magazine and tool changing cycle.

H 38

Boring bar adaptors for multi-task machining

Radial mounting

ASHA

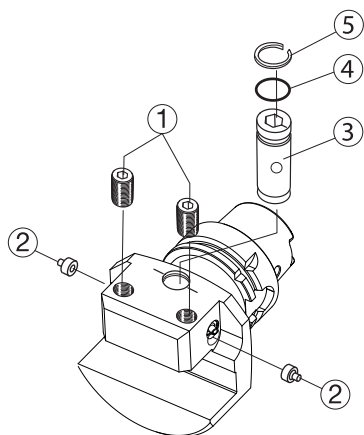

	1	2	3	4	5
	Screw	Coolant nozzle (thread)	Valve bolt	O-ring	Circlip
392.419-63-ASHA-25	3214 020-512	5691 034-02 (M10) ¹⁾	5692 035-04	5641 005-79	3421 105-015 (SB15)
392.419-100-ASHA-32	3214 020-512	5691 034-02 (M10) ¹⁾	5692 035-04	5641 005-79	3421 105-015 (SB15)

1) When changing nozzle use key 5680 019-01 and bits 5680 021-03

Axial mounting

ASHR/L

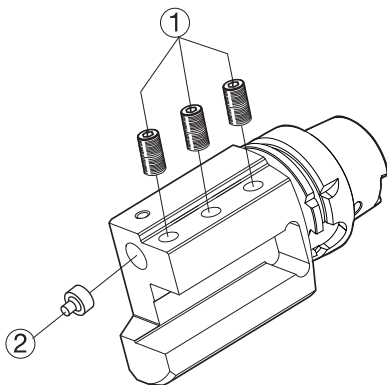

	1	2
	Screw	Coolant nozzle (thread)
392.419-63-ASHR/L-25	3214 020-512	5691 034-02 (M10) ¹⁾
392.419-100-ASHR/L-32	3214 020-512	5691 034-02 (M10) ¹⁾

1) When changing nozzle use key 5680 019-01 and bits 5680 021-03

Boring bar adaptors for multi-task machining

HSK form A/C/T

Axial mounting

B

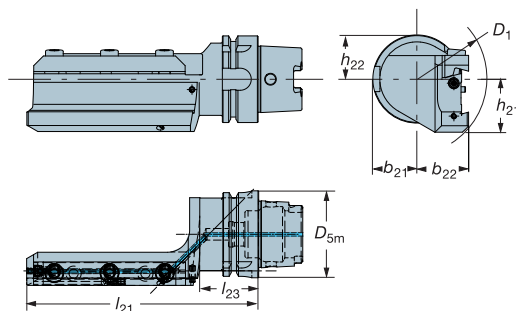

C

Right hand style shown

For blade size	HSK size	Ordering code	Dimensions, mm, inch								
			D_{5m}	b_{21}	b_{22}	D_1	h_{21}	h_{22}	l_{21}		l_{23}
25	63	392.419-63-APBR/L-25	63	31.5	37	100	38	31.5	168	42	2.07
			2.480	1.240	1.457	3.937	1.496	1.240	6.614	1.654	

R = Right hand, L = Left hand

G

Warning!

The adaptors are designed for automatic tool change.
Make sure that there is no risk of interference in magazine and tool changing cycle.

Main spare parts

H

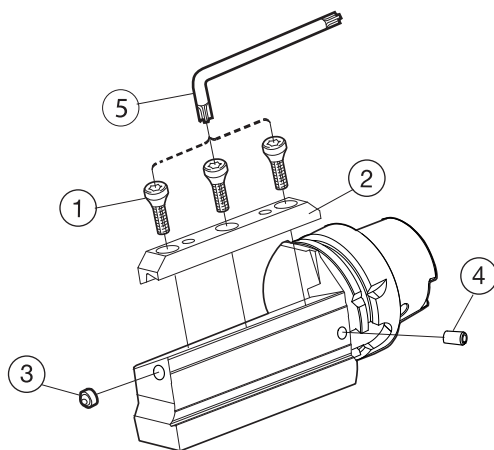

I

	1	2	3	4	5
Holder	Screw	Clamp	Nozzle	Spring pin	Key (mm)
392.419-63-APBR/L-25	3212 010-411	5412 120-02	5631 034-01	3113 030-457	3021 010-060 (6.0)

J