

Heavy duty T-MAX 45 milling cutter

T-MAX 45 is a system of adjustable coarse differential pitch or close pitch facemills suitable for high metal removal in powerful milling machines or machining centres.

The 45° entering angle and the strong inserts allow the cutters to be used under demanding conditions, including long spindle overhangs.

The 6.4 mm thick inserts offer excellent cutting edges with body security, and provide a maximum cutting depth of 12 mm. The improved reliability, due to reduced risk of cutter failure, ensures minimum machine downtime. The inserts also have 2 mm parallel lands and secondary cutting edges which provide an effective back cutting facility.

The wiper insert is suitable for finish machining, but it is important that a wiper insert seat is fitted to ensure the position of the wiper edge is secure.

When the basic setting of the cutter has been fixed, the wiper edge will be most effective, and vibration avoided, if the axial depth of cut does not exceed 0.5 mm.



Diameter 100 – 400 mm

Adjustable

Positive/negative rake

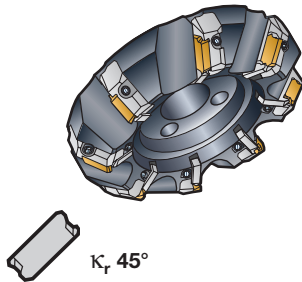

Materials:
Steel, stainless steel, cast iron

Inclination angle: +12°

Top rake angle: LNCX-11: -8°
LNCX-31/32: +9°

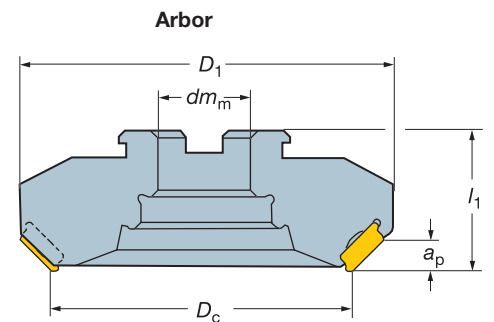

l_1 = programming length

Application

Roughing



LNCX -11



LNCX -31
LNCX -32

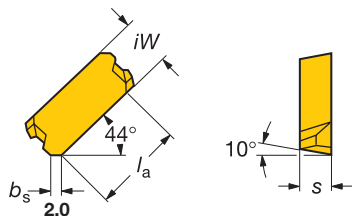

LNCX-1W
Wiper

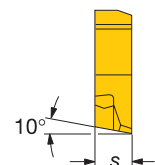
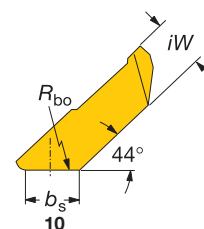

Medium

The cutter is axially adjustable within 5 μ m.

Axial adjustment can be performed by two screws acting against the tab on the back of the shim.

In case of damage, the shim can normally be replaced without influencing the axial setting.

Adjustment

The cutter is axially adjustable within 5 µm.

Axial adjustment can be performed by two screws acting against the tab on the back of the shim.

In case of damage, the shim can normally be replaced without influencing the axial setting.

Basic setting of the cutter should be performed according to instruction C8228:101.

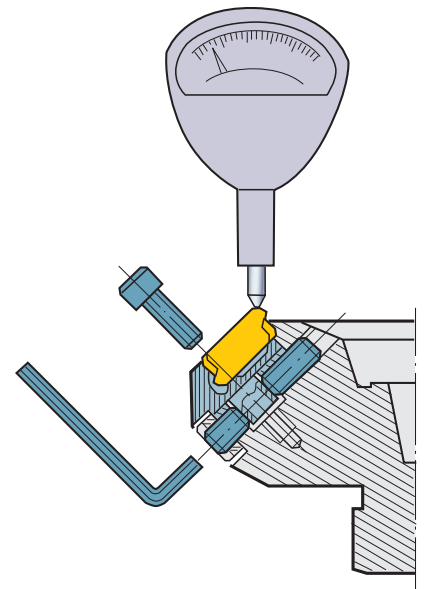

Spring clamping of the inserts

The quick and easy-to-handle insert clamping system contributes to more troublefree production, reducing costs considerably with subsequent improved productivity.

	Insert code l_a	Dimensions, mm				
		s	iW	b_s	a_p	max
18	LNCX 18 06 AZ R-11	18.77	6.4	10	2.0	12
	18 06 AZ R-31	18.62	6.4	10	2.0	–
	18 06 AZ R-32	18.62	6.8	10	2.2	–
18	Wiper	iW	s	b_s	R_{bo}	–
	LNCX 18 06 AZ R-1W	9.28	10.5	10	400	–

Wiper

LNCX

LNCX in Wiper shim

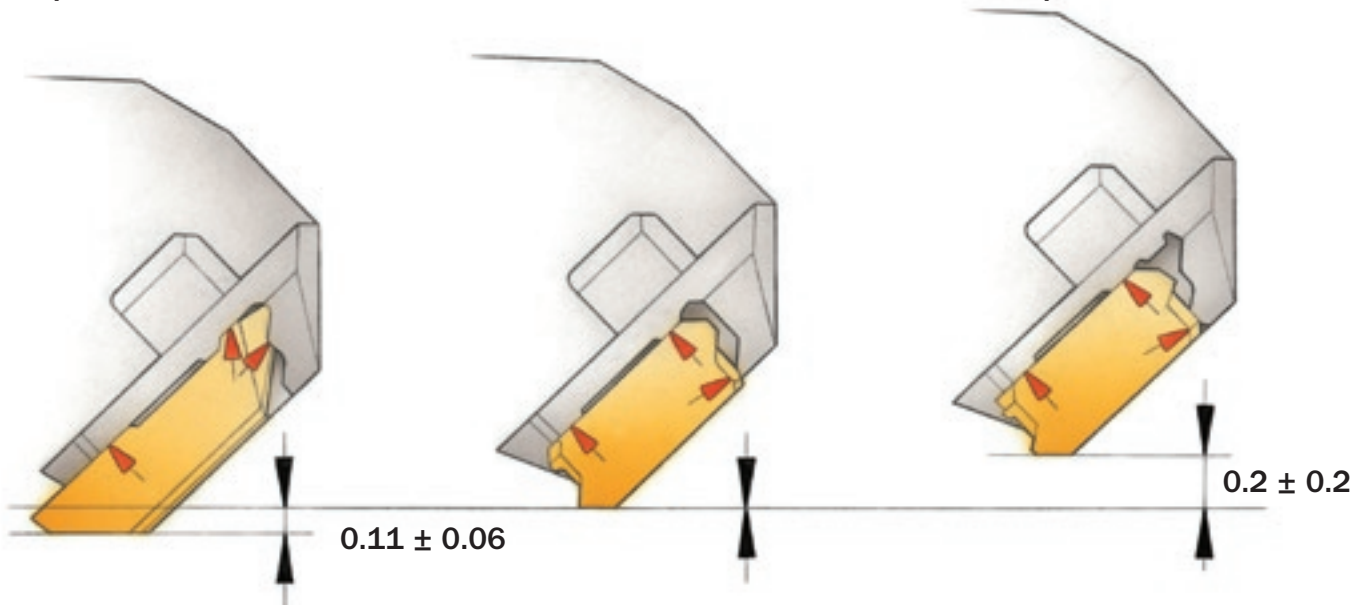

Sandvik AUTO and T-line cutters roughing and finishing milling cutter

The Auto and Auto Cap are extra close pitch facemills primarily intended for roughing and semi finishing of cast iron components.

The large number of inserts enables large table feeds giving very good machining economy.

Sandvik AUTO cutters use triangular inserts which are available in several different geometries, optimized for different operations.

All of the inserts are double sided, providing six right-hand and six left-hand cutting edges. The large number of cutting edges provide excellent tooling economy.

The T-Line milling cutters are developed for machining cast iron and steel components. They offer good security and economy through the use of tangentially mounted inserts. The R260.75 facemill utilizes LNE 323 style inserts.

When the demands on surface finish are more acute the LNE 323-PL1 inserts with parallel land are recommended. The R260.90 square shoulder cutter utilizes CDE 322 style inserts.

The insert geometries are available in LNE and CDE styles and in many different sizes and varieties of corner configuration.

Auto-R

- Extra close pitch facemills primarily intended for roughing and semi-finishing of cast-iron components.

Auto-AF

- Adjustable facemilling cutter for finishing of cast-iron components demanding high quality surface finishes.

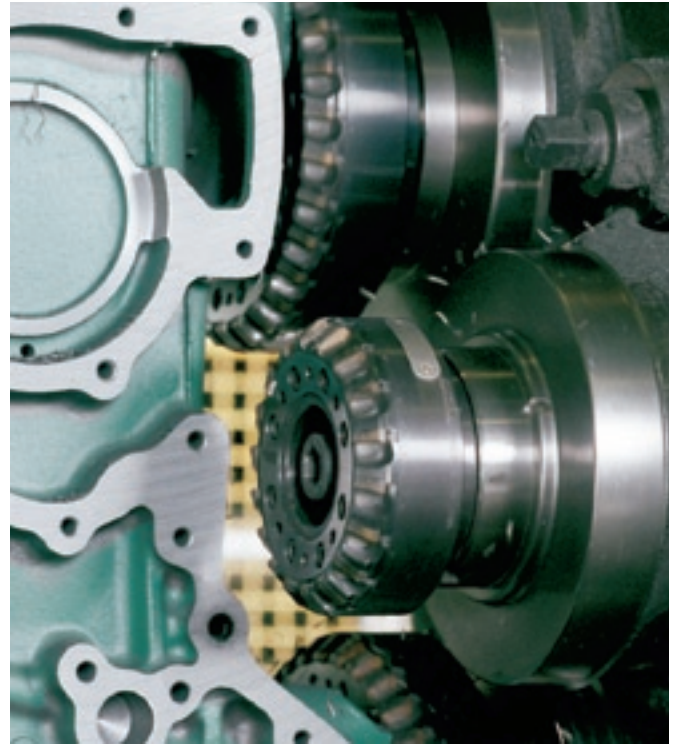

Auto-FS

- Fixed pocket facemilling cutter designed for square shoulder cast-iron applications demanding fine surface finishes at high feed rates.

Rough machining

Facemill –AUTO

Diameter 80 - 500 mm

Negative rake

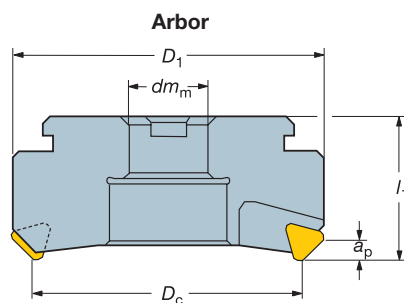
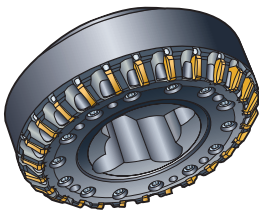

R/L260.3

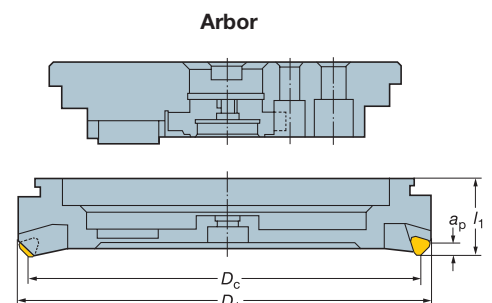

R/L260.31 (Cap design)

Machines: Transfer lines and milling machines

Material: Cast iron

Inclination angle: -4°

Top rake angle: -7°

l_1 = programming length

Auto inserts

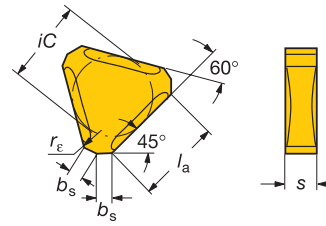
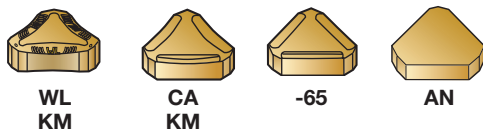

A

B

C

D

		GC = Coated carbide/Cermet (ISO = HC) CC = Ceramics (ISO = CA, CM, CN, CC) - = Uncoated carbide (ISO = HW)						
		Dimensions, mm						
		Insert code	iC	s	b _s	l _a	r _ε	a _p max
LIGHT	12	TNHF 12 04 AN-WL	12.7	4.76	1.75	12	2	6
		TNEF 12 04 AN-WL	12.7	4.76	1.75	12	2	6
		TNCN 12 04 ANE	12.7	4.76	1.75	12	-	6
MEDIUM	12	TNHF 12 04 AN-CA	12.7	4.76	1.5	12	3	-
		TNEF 12 04 AN-CA	12.7	4.76	1.5	12	3	-
		TNEF 12 04 AN-KM	12.7	4.76	1.5	12	3	-
		TNHF 12 04 AN-65	12.7	4.76	2.5	12	-	-
		TNEF 12 04 AN-65	12.7	4.76	2.5	12	-	-
		TNCN 12 04 AN	12.7	4.76	2.5	12	-	-
HEAVY	12	TNJNI 12 04 AN	12.7	4.76	2.5	12	-	-
		TNEN 12 04 AN	12.7	4.76	2.5	12	-	-

E

F

G

H

Auto

TNHF-WL/TNEF-WL

- Extra positive Waveline geometry
- Low cutting forces
- Excellent for milling thin walled components
- Intermediate corner radii reduce workpiece frttering
- Close E-tolerance minimizes radial/axial run-out
- Double sided

Feed range

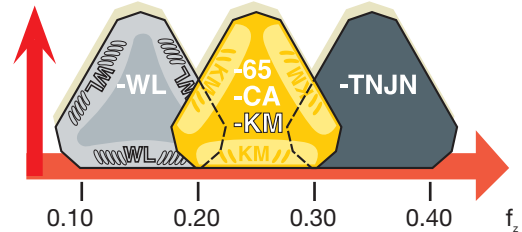

TNHF-KM/TNEF-KM, general application

- The positive Waveline geometry with strong cutting edges increase productivity by up to 25%
- Intermediate corner radii reduce workpiece frttering
- Close E-tolerance minimizes radial/axial run-out
- Double sided

TNHF-65/TNEF-65

- All-round geometry for semi-finishing operations
- Complement to TNHF-CA
- Double sided

TNJNI, TNEN and TNCN

- Negative inserts give extra strong cutting edges
- High feeds per tooth
- Ceramic cutting material CC6090 (TNCN)
- Relatively high cutting forces
- At their best in stable machines and fixtures
- Double sided

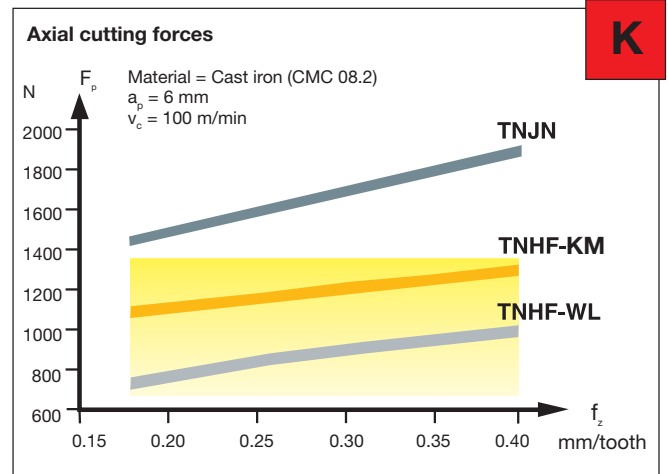

Sandvik AUTO -AF adjustable cutter for facemilling

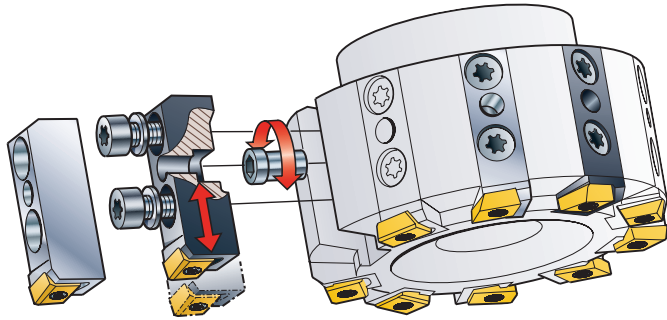

The Auto -AF cutters are intended for finishing of cast iron and nodular iron components, to high quality surface finish demands.

Easy high precision setting within ± 0.002 mm, by means of eccentric pin and safe locking of cassettes by two screws. Adjustable within the whole working area, approx. 1 mm. Maximum depth of cut = 1 mm.

Facemill AUTO AF
 Diameter 80 – 500 mm
 Adjustable
 Positive

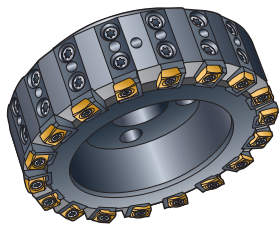

Machines: Machining centres, transfer lines and milling machines

Materials: Cast iron
 Inclination angle: $+10^\circ$
 Top rake angle: -8°

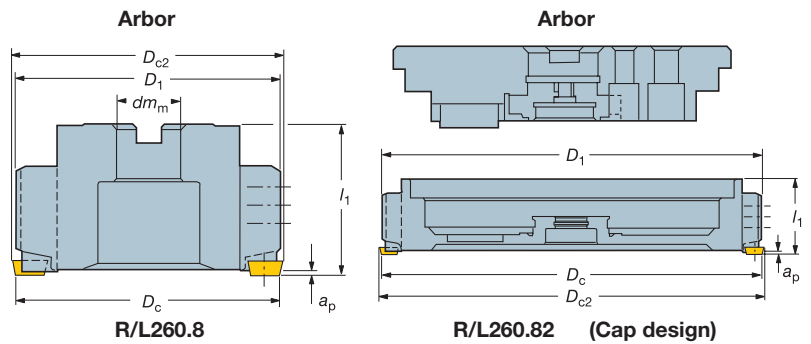

l_1 = programming length



Mounting the insert

Apply Molykote 1000 on insert screw head and thread.

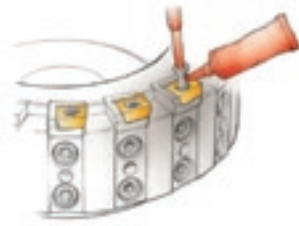

Clean the insert seat thoroughly before commencing. Ensure contact against the three support points in the insert seat. Tighten the screw to a torque of 3 Nm.



Setting instructions for Sandvik AUTO-AF adjustable finishing cutters

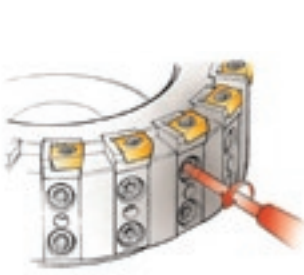

For cutter setting use:
Diabase surface plate
Micro-indicator
Key 265.2-821
Key 5680 048-07 (30IP)
Torque wrench

Tighten the cassette screws to approx. 2 Nm.

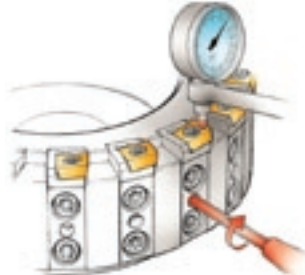

Place the cutter on the diabase surface plate. Locate the highest point on the insert edge to the flat contact point of the micro indicator. Turn the eccentric pin and move the cassette with insert to a zero reading on the indicator.

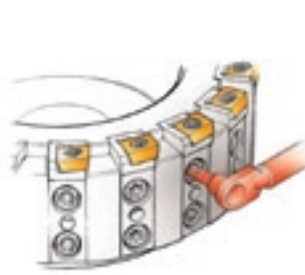

Fasten the cassette screws to 16-Nm, using a torque wrench, Torx bit 5680 084-10.

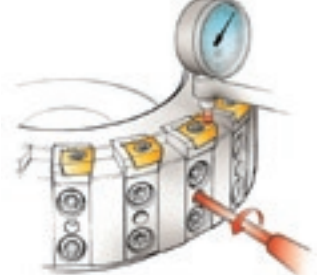

Finally loosen the eccentric pin to set insert height and prevent risk of axial run out.

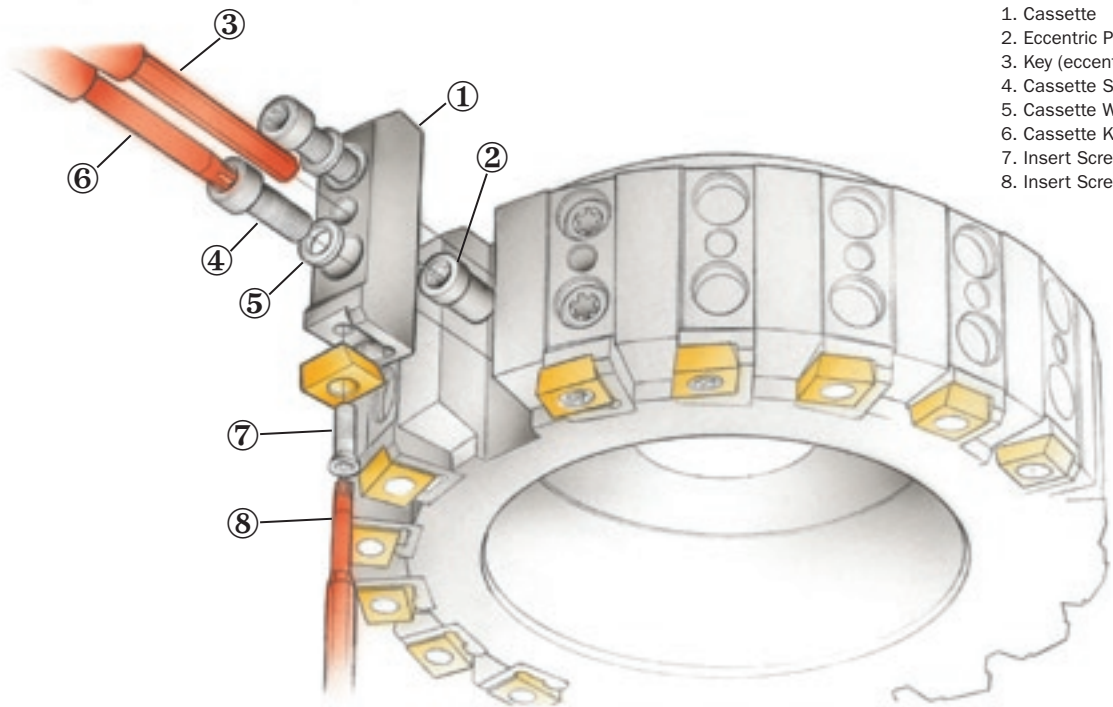

1. Cassette
2. Eccentric Pin
3. Key (eccentric pin adj.)
4. Cassette Screw
5. Cassette Washer
6. Cassette Key
7. Insert Screw
8. Insert Screw Key

Inserts for AUTO AF — Finishing

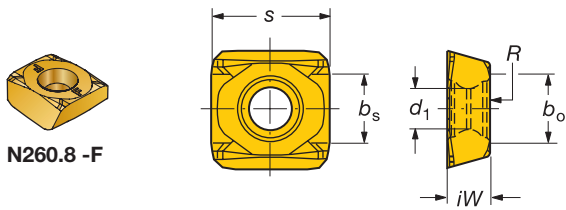

N260.8 -F

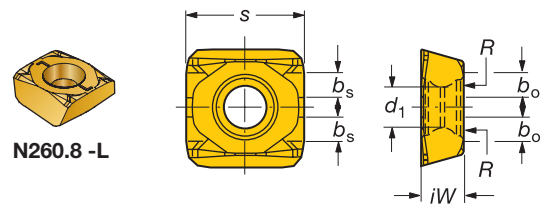

N260.8 -L

Insert design

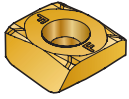

Type F, wiper

– with long parallel lands and four cutting edges/insert, right or left hand.

To be used where high quality surface finish is required.

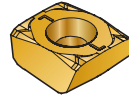

Type L

– with shorter parallel lands, have four right and four left hand cutting edges/insert.

Low axial cutting forces facilitate milling of modern, thin walled components on weak machines, where L inserts should be used.

L inserts can also be used in combination with F inserts.

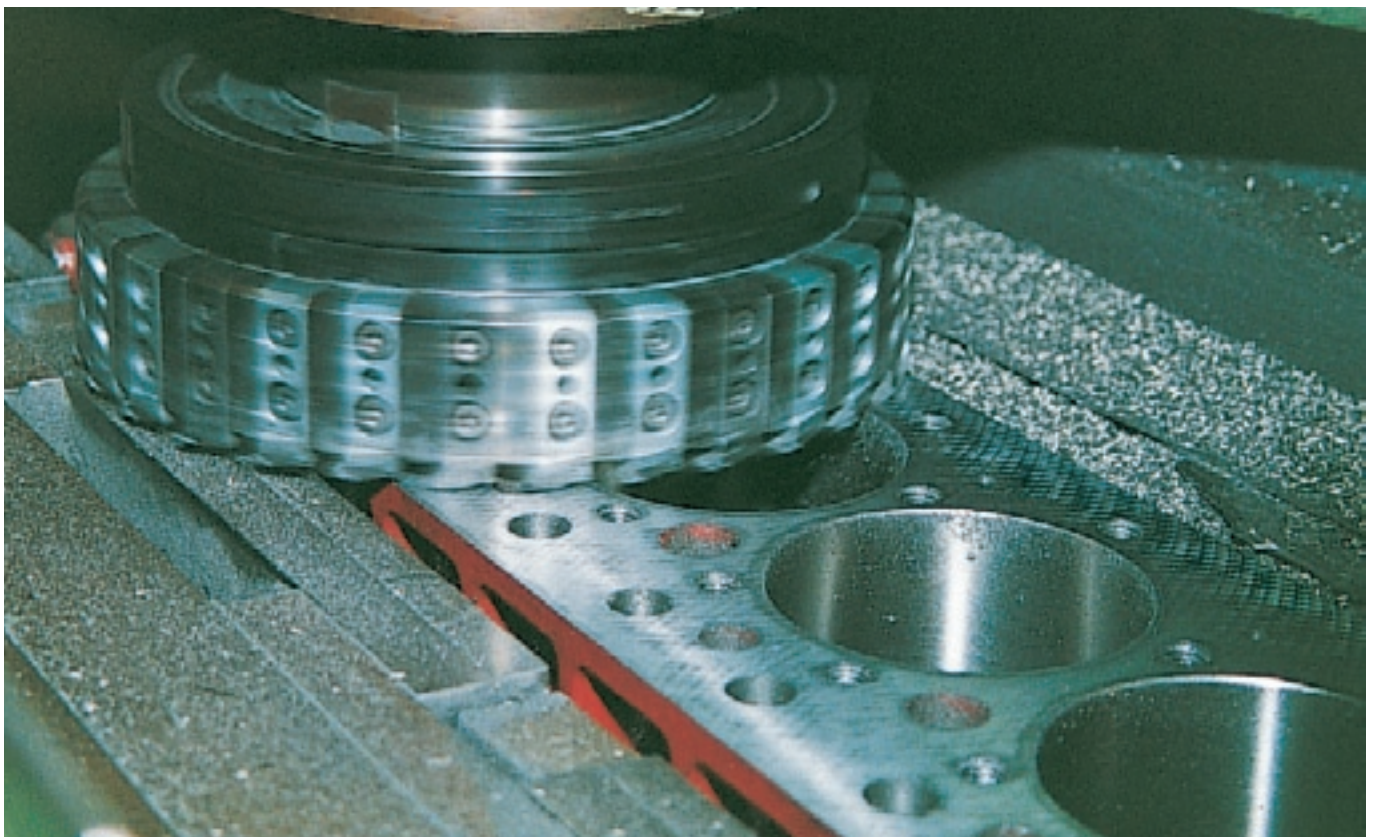

Square shoulder facemill Auto-FS

The extra close pitch Auto-FS and Auto-FS Cap cutters are designed for milling square shoulders and facemilling to very fine surface quality at high feed rates.

Inserts provide a cutting edge length of 12 mm and cutting depths of up to 8 mm are possible.

A

Diameter 125 – 500 mm

Negative rakes

B

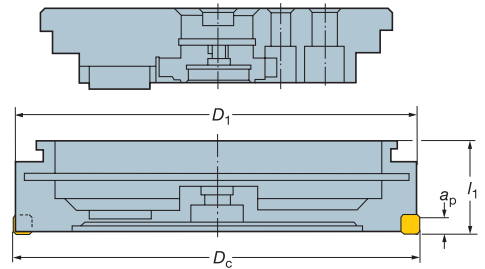
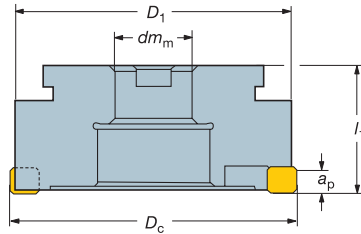
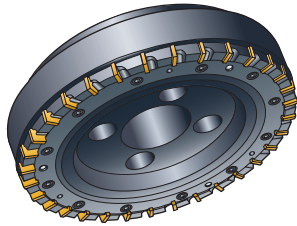

C



R/L262.4

R/L262.42 (Cap design)

Materials: Cast iron
Inclination angle: -4°
Top rake angle: -2°

l_1 = programming length

D

Inserts for Auto-FS

Finishing



SBEN

SBEX

SBEX-11

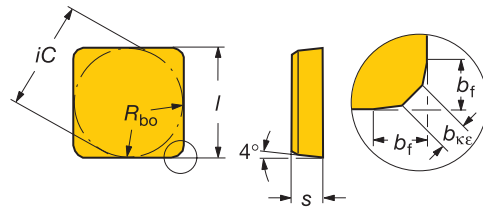

E

SBEN

- Coated grade for high cutting speed
- Wiper insert combined with SBEX -11 inserts
As a wiper insert it will automatically be positioned 0.05 mm below the SBEX -11 inserts.
- Optimized corner geometry

SBEX

- Negative chipformer with strong cutting edges
- Use SBEN as wiper insert
- Coated grades for high cutting speeds

SBEX-11

- Positive chipformer generates lower cutting forces, appr. 30%, eliminating vibration
- Use SBEN as wiper insert

F

G

H

Insert code	Dimensions, mm				
	$l = iC$	s	b_f	b_{ke}	R_{bo}
12 SBEN 12 04 ZZ	12.7	4.74	1.2	0.7	2960
SBEX 12 04 ZZ	12.7	4.74	1.2	0.7	2960
12 04 ZZ-11	12.65	4.76	-	0.8	-

Spacers for adjusting spindle inclination

The parallel land of the insert can be adjusted according to the spindle inclination. Spacers mounted in the support body for spindle inclination 0.1:1000, are shown below.

Cutter diameter (D _c)	Spacers
250	0.02 mm
315	0.05 mm
355	0.05 mm
400	0.02 and 0.05 mm
500	0.02 and 0.05 mm

For other spindle inclinations, a spacer set, ordering code 260-836-1, can be ordered separately. The dimensions for different inclinations are shown on the graph.

Spindle inclination/spacer thickness

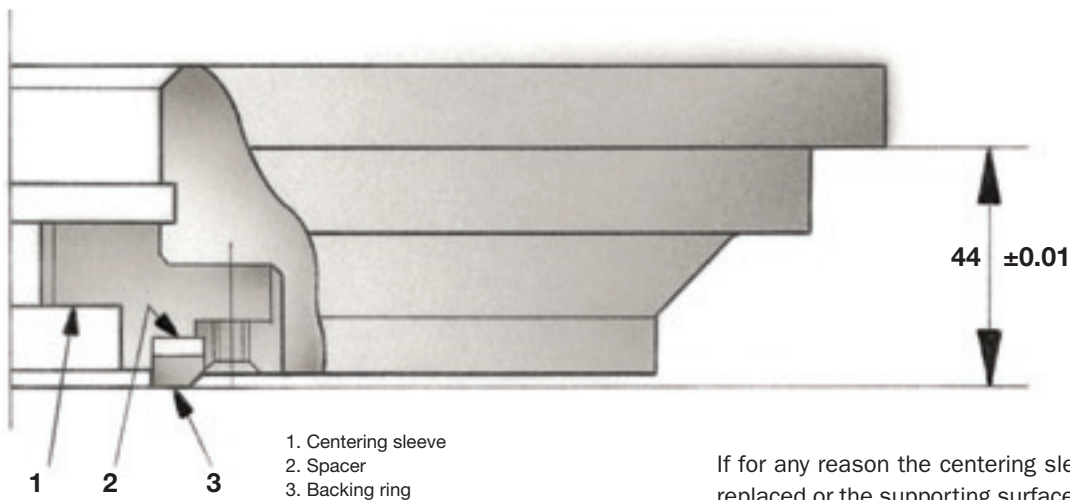
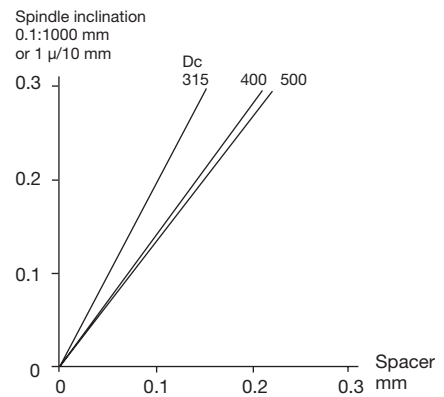

If for any reason the centering sleeve or backing ring must be replaced or the supporting surface reground, the 44 ± 0.01 mm dimension must be adjusted with spacers.

Auto-CAP System

- Both the roughing and finishing facemill of this system are characterized by their light weight as well as their improved production economy in combination with precision.
- The main features of the AUTO-CAP system are:
 - Reduced handling weight.
 - One central screw instead of four to hold unit to the spindle.
 - Spring-loaded wedges for retaining inserts.
 - Replaceable seating ring.
 - SUPPORTING body mounted on the spindle gives the necessary spindle rigidity and utilizes the fly-wheel effect.

T-Line milling cutters

Secure machining in cast-iron and steel

The T-Line milling cutters are intended for machining cast iron and steel components.



A

They offer good security and economy through the use of tangentially mounted inserts.

The R260.75 facemill utilizes LNE 323 style inserts.

When the demands on surface finish are more acute the LNE 323-PL1 inserts with parallel land are recommended.

The R260.90 square shoulder cutter utilizes CDE 322 style inserts.

B

Tangentially mounted milling inserts

The insert geometries are available in LNE and CDE styles and in many different sizes and varieties of corner configuration.

Other corner configurations are available as Tailor Made.

C

Facemill

Diameter 80 — 250 mm
Negative rake

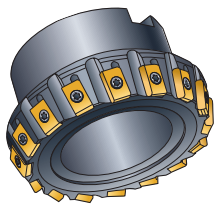
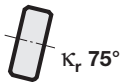

Machines: All types

Materials: Steel, cast iron, heat resistant materials

Inclination angle: -6°
Top rake angle: -10°

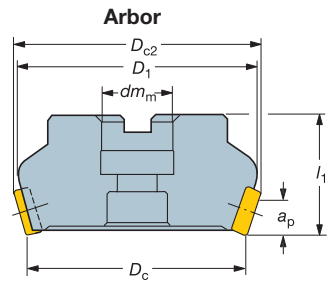

D

E

Square shoulder facemill

Diameter 80 — 250 mm
Positive rake

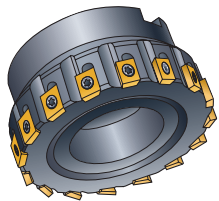
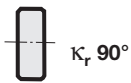

Machines: All types

Materials: Steel, cast iron, heat resistant materials

Inclination angle: 2°
Top rake angle: 10°

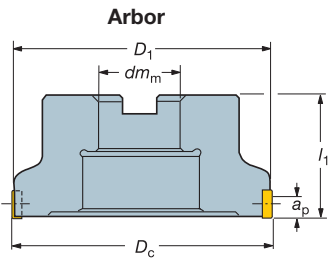

F

T-Line roughing inserts

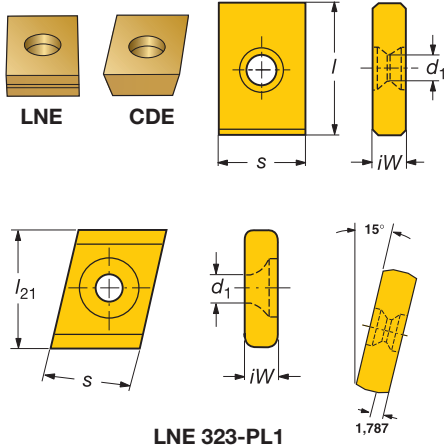

Insert code	Dimensions, mm					R = Radius C = Chamfer ¹⁾ P = Parallel land
	l_{21}	s	d_1	iW	l	
15 LNE 323-02 323-04 323-PL1	15.875	-	9.525	4.27	4.76	C 0.787 x 45° R 1.575 P 1.787 x 13°
12 CDE 322 R02 322 R05 322 L05	-	12.70	9.525	4.27	3.81	R 1.575 R 0.787 R 0.787

G

H

Sandvik Auto cylinder boring cutter

A positive cutter for roughing of cylinder bores.

- A Tailor Made concept for most cylinder bores currently on the market.
- Operates with low cutting forces.
- Improved bore size control, better consistency.
- Reduced tool and service costs.
- Inserts with parallel land result in better surface, i.e. reduced withdrawal marks.
- The grade profile provides the right grade for any material and cutting data.
- Recommended cutting depth 1–6 mm.

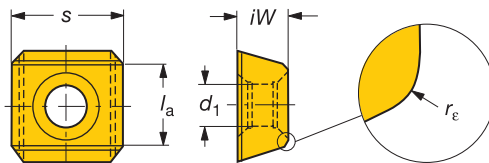

ISO	Insert code	Dimensions, mm				
		s	l_a	d_1	iW	r_ϵ
15	SDKX 15 06 ZN	15	11	5.6	6.35	-
	SDKX 15 06 08	15	11	5.6	6.35	0.8
	SDKX 15 06 ZN	15	11	5.6	6.35	-
	SDKX 15 06 08	15	11	5.6	6.35	0.8
	SDKX 15 06 ZN	15	11	5.6	6.35	-
	SDKX 15 06 08	15	11	5.6	6.35	0.8

Cutting data

ISO	CMC No.	Material		Hardness Brinell	GC3015	GC3040	H13A
					Feed mm/tooth		
					0.4 – 0.1	0.4 – 0.1	0.4 – 0.1
				Cutting speed m/min			
K	07.1	Malleable cast iron	Ferritic (short chip)	110 – 145	200 – 300	120 – 240	60 – 85
	07.2		Perlitic (long chip)	200 – 230	100 – 200	85 – 175	50 – 75
	08.1 08.2	Grey cast iron	Low tensile, High tensile,	180 260	120 – 400 80 – 300	110 – 250 80 – 200	70 – 100 50 – 90
09.1 09.2	Nodular SG iron	Ferritic Pearlitic	160 250	200 – 250 80 – 180	100 – 160 70 – 140	50 – 80 40 – 75	

This catalogue has been split into smaller parts
to enhance downloading speeds.

If you want to view the next page
please click [HERE!](#)