

SH. 1
OF 1

CAT NO

1019M-25

CUSTOMER DIMENSIONS

DO NOT
SEPARATE
PRINT FROM
WORK

LOT NO

OPER

TOOLS

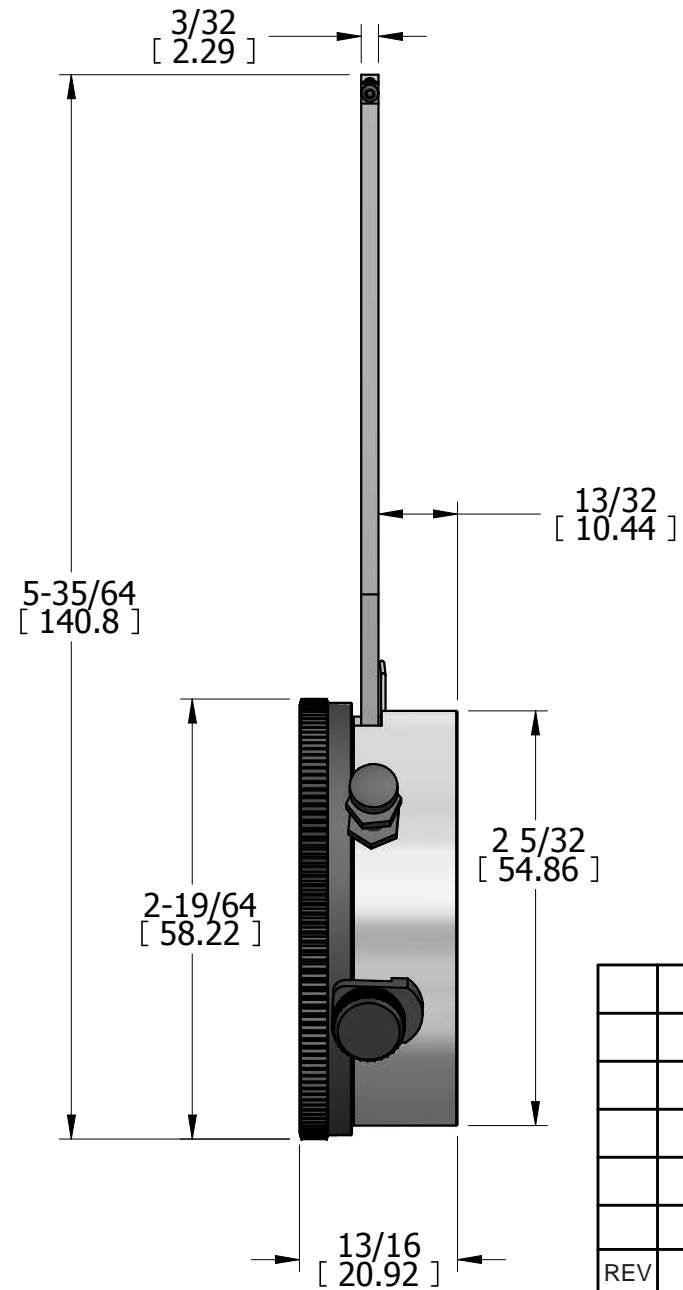
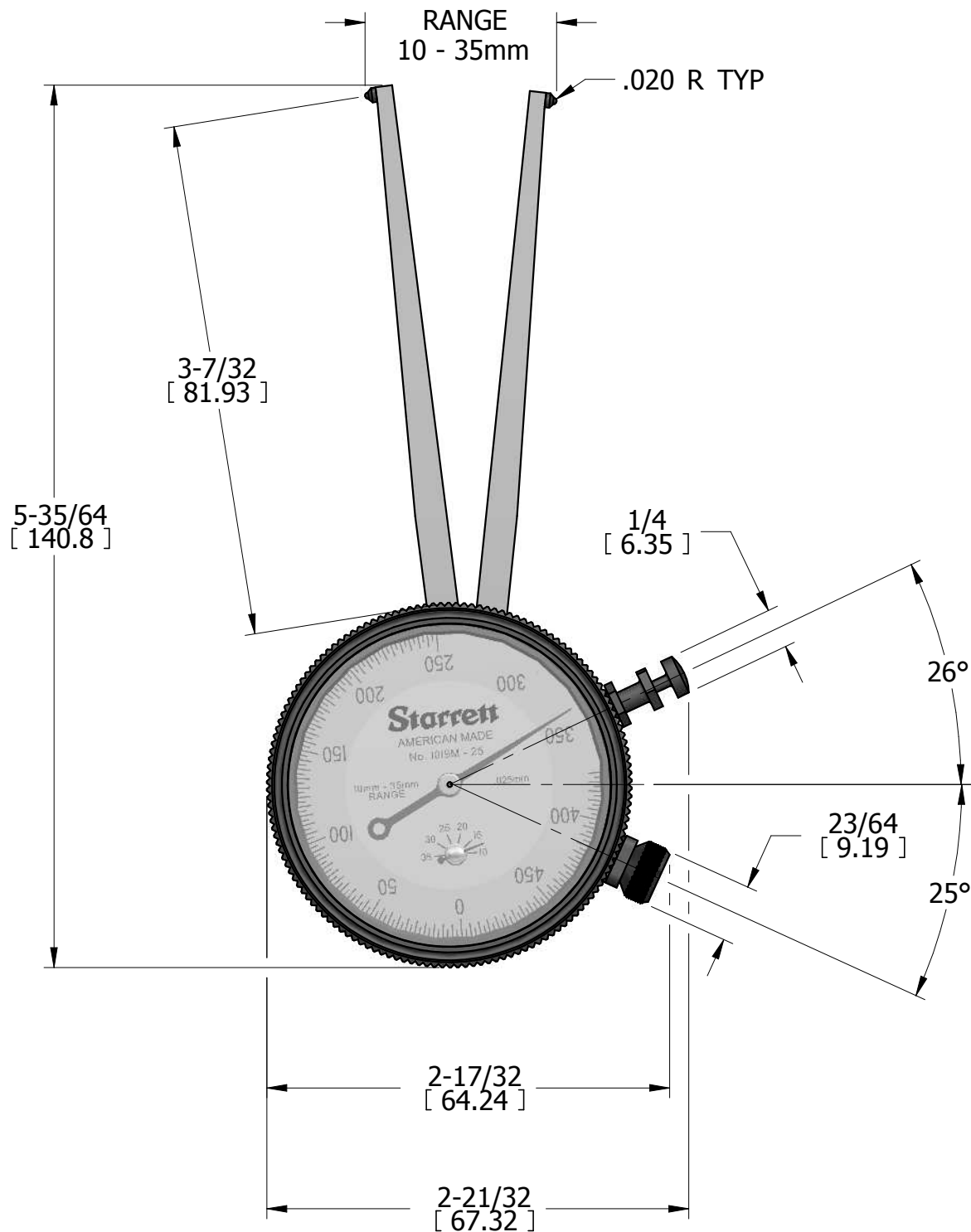

REV	DESCRIPTION	DATE	BY
DR	CAP	CHK	DATE 1/29/15

INTERNAL TYPE
CALIPER GAGE

THE L.S. STARRETT CO.
ATHOL, MASS.

FRACTIONAL TOLERANCE $\pm \frac{1}{64}$ UNLESS OTHERWISE NOTED