

SH. 1  
OF 1

CAT NO

120AM-150

CUSTOMER DIMENSIONS

DO NOT  
SEPARATE  
PRINT FROM  
WORK

LOT NO

OPER

TOOLS

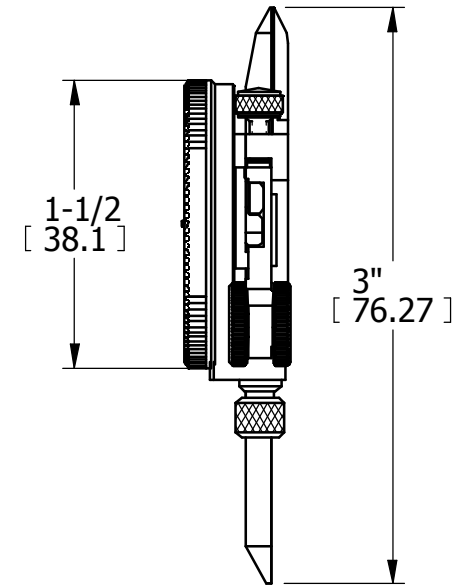
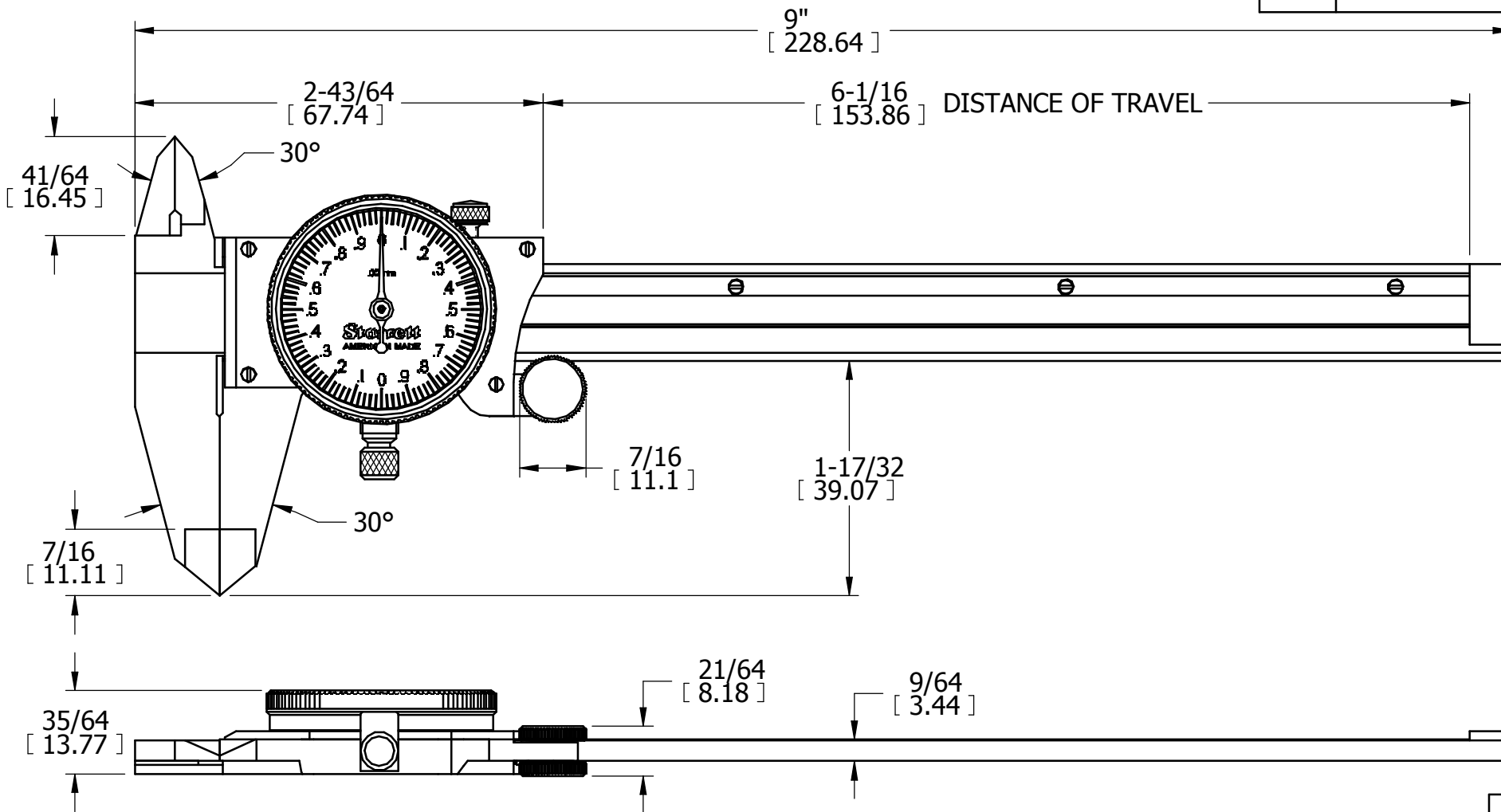

REV	DESCRIPTION	DATE	BY
DR	MJR	CHK	DATE

DIAL CALIPER  
ASSEMBLY  
-METRIC-

THE L.S. STARRETT CO.  
ATHOL, MASS.

FRACTIONAL TOLERANCE +- 1/64 UNLESS OTHERWISE NOTED