

SH. 1
OF 1

CAT NO

120MB-300

CUSTOMER DIMENSIONS

DO NOT
SEPARATE
PRINT FROM
WORK

LOT NO

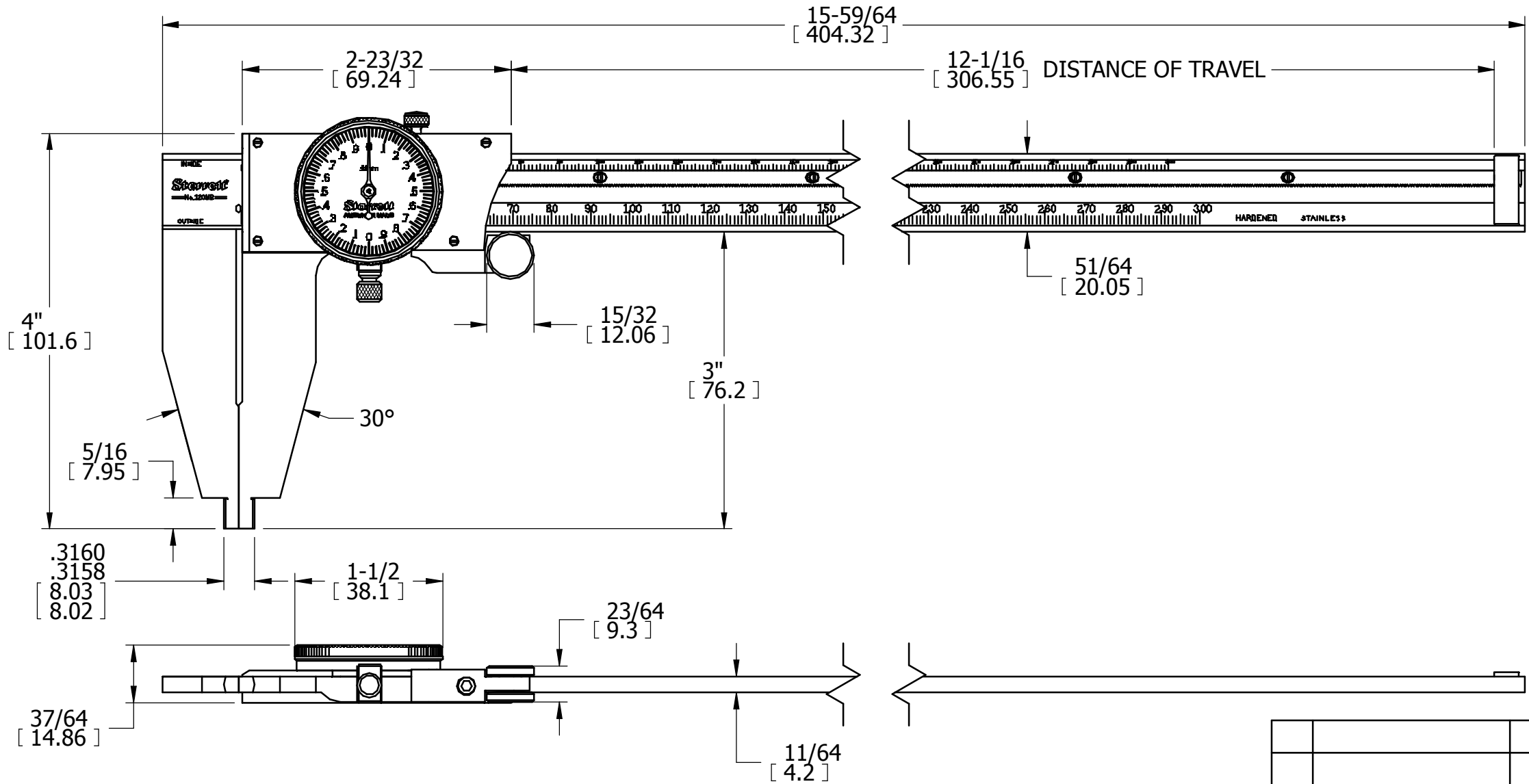

REV	DESCRIPTION	DATE	BY
DR	DS	CHK	DATE

METRIC - DEEP JAW
DIAL CALIPER
ASSEMBLY

THE L.S. STARRETT CO.
ATHOL, MASS.

FRACTIONAL TOLERANCE +- 1/64 UNLESS OTHERWISE NOTED