

SH. 1  
OF 1

CAT NO

132-9

CUSTOMER DIMENSIONS

DO NOT  
SEPARATE  
PRINT FROM  
WORK

LOT NO

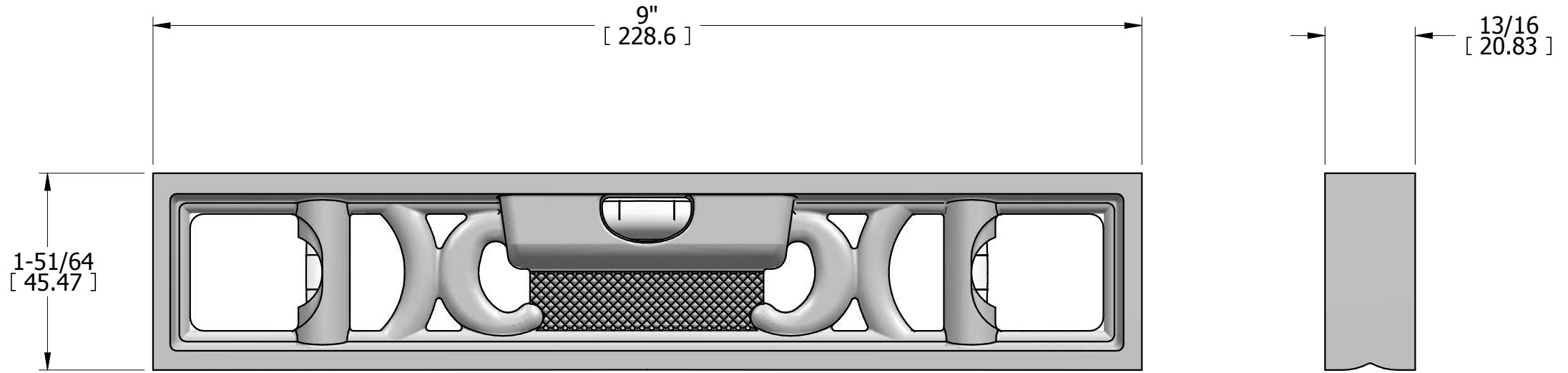

REV	DESCRIPTION	DATE	BY
-----	-------------	------	----

DR	CHK	DATE
----	-----	------

**BENCH LEVEL  
W/DOUBLE PLUMBS  
ASSEMBLY**

**THE L.S. STARRETT CO.  
ATHOL, MASS.**

FRACTIONAL TOLERANCE +- 1/64 UNLESS OTHERWISE NOTED