

SH. 1
OF 1

CAT NO

208Z

CUSTOMER DIMENSIONS

DO NOT
SEPARATE
PRINT FROM
WORK

LOT NO

OPER

TOOLS

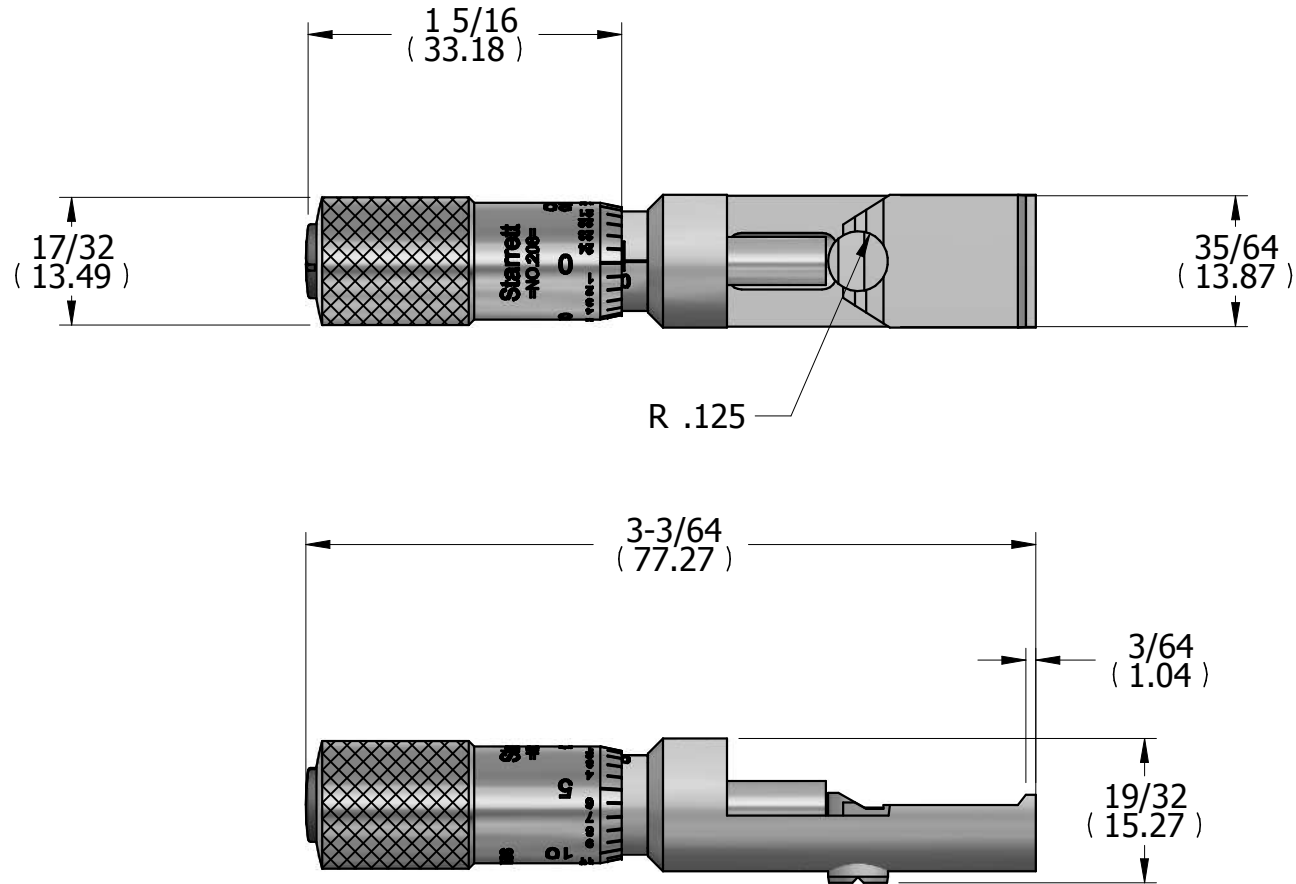

REV	DESCRIPTION	DATE	BY
-----	-------------	------	----

DR	E.G.H.	CHK	DATE
----	--------	-----	------

SEAM & C'SINK
DEPTH MEASUREMENT
MICROMETER

THE L.S. STARRETT CO.
ATHOL, MASS.

FRACTIONAL TOLERANCE +- 1/64 UNLESS OTHERWISE NOTED