

OPER

TOOLS

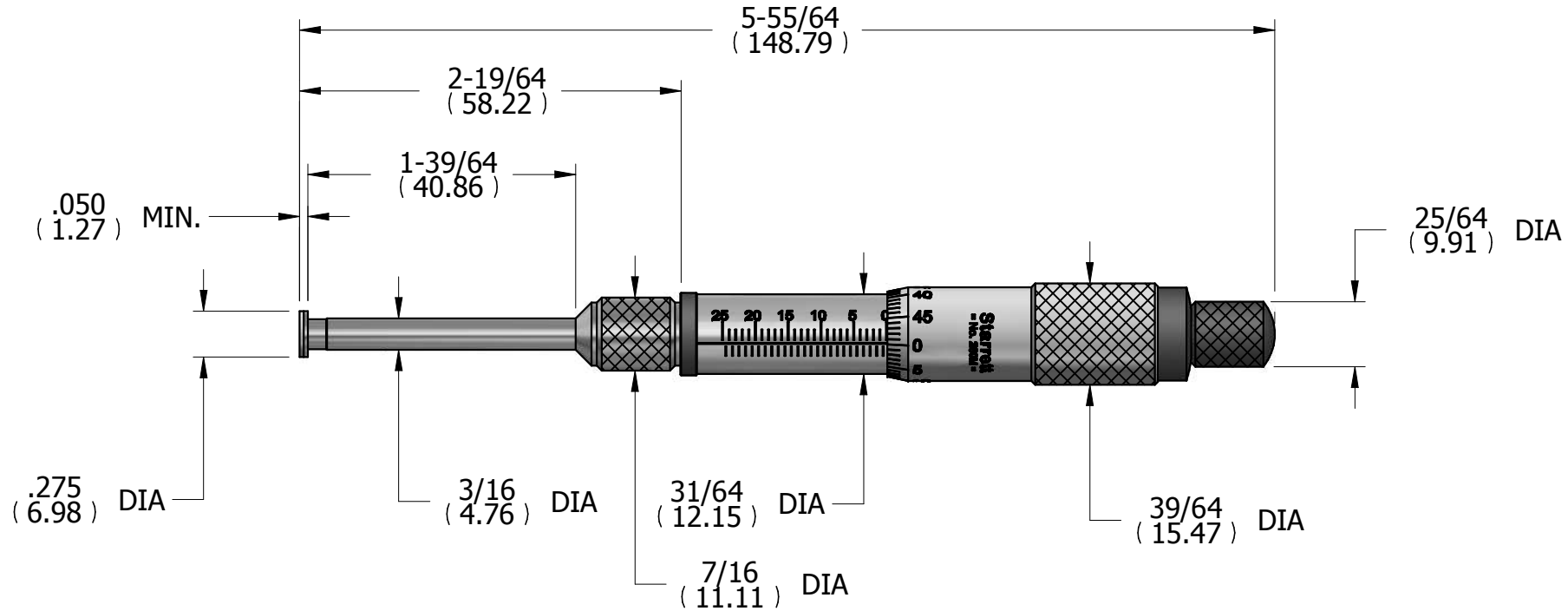

REV	DESCRIPTION	DATE	BY
-----	-------------	------	----

DR	D.C.A.	CHK	DATE
----	--------	-----	------

GROOVE MICROMETER
ASSEMBLY

FRACTIONAL TOLERANCE +- 1/64 UNLESS OTHERWISE NOTED

THE L.S. STARRETT CO.
ATHOL, MASS.