

D	MIN. DIA. ADDED	3/2/16	SMB
REV	DESCRIPTION	DATE	BY
DR	KPH	CHK	DATE

SHAFT ALIGNMENT  
CLAMP

THE L.S. STARRETT CO.  
ATHOL, MASS.

FRACTIONAL TOLERANCE +/- 1/64 UNLESS OTHERWISE NOTED

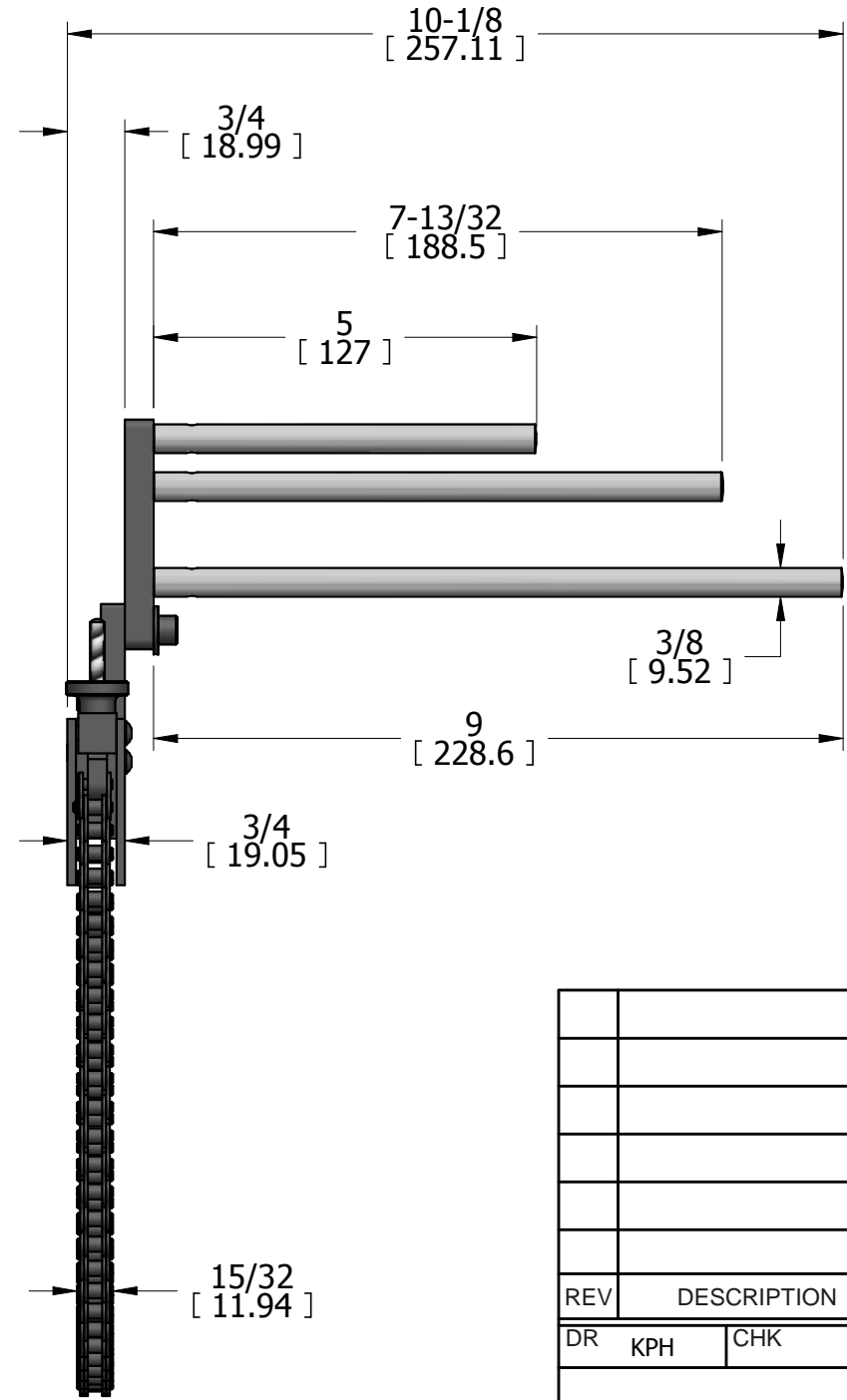
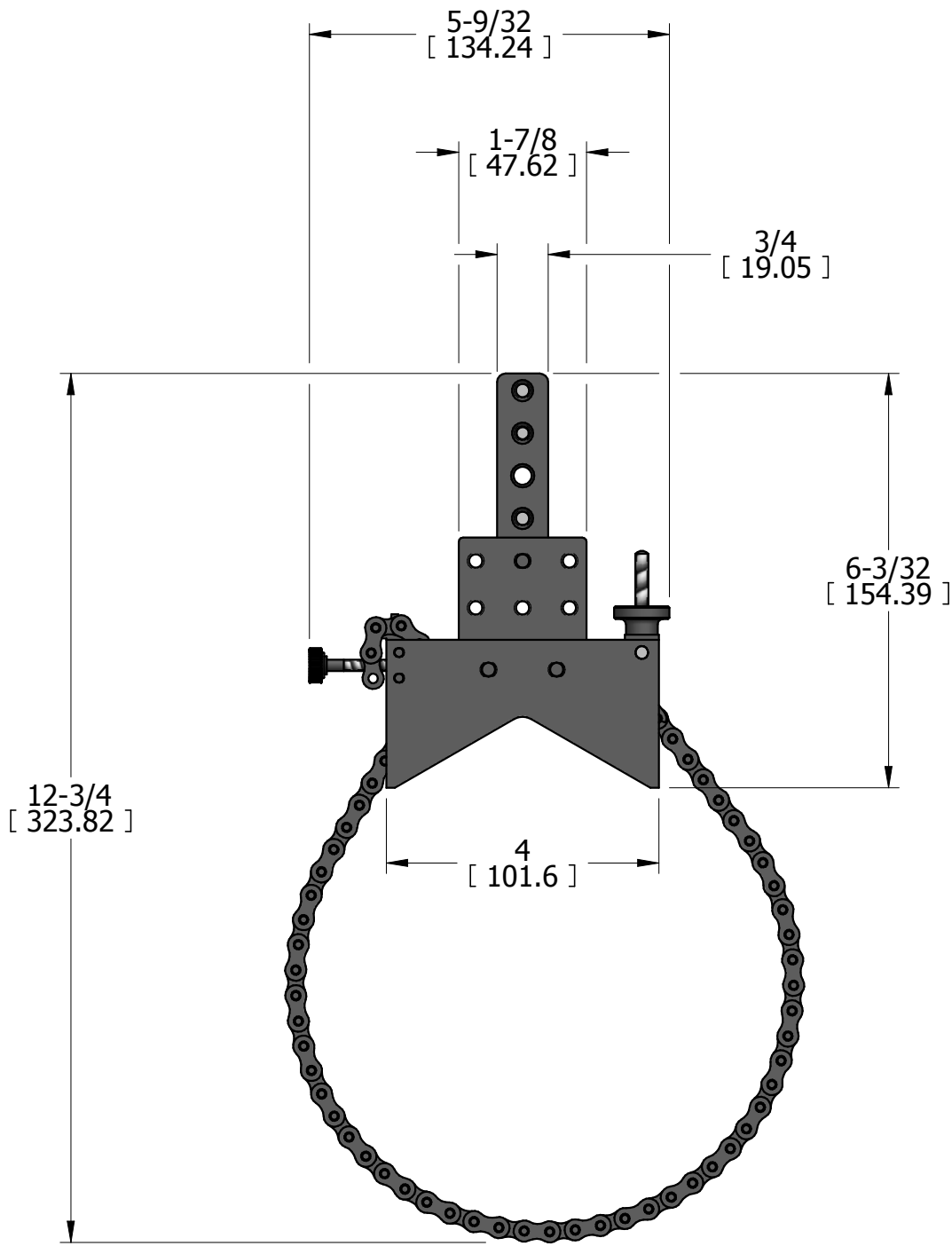

REV	DESCRIPTION	DATE	BY
-----	-------------	------	----

DR	KPH	CHK	DATE
----	-----	-----	------

SHAFT ALIGNMENT  
CLAMP

THE L.S. STARRETT CO.  
ATHOL, MASS.

FRACTIONAL TOLERANCE +- 1/64 UNLESS OTHERWISE NOTED